



1718 W. Fullerton Chicago, IL 60614
 Ph: 773.770.1195 • Fax: 773.935.5613
 www.PureEdgeLighting.com • info@PureEdgeLighting.com
 © 2016 PureEdge Lighting. All Rights Reserved.

Installation Instructions for Vanishing Point Dual Suspension Grip Jack 24 Volt with Remote Power

VR-DGJ24S_

IMPORTANT INFORMATION

- This instruction shows a typical installation.
- This product is ceiling mount.

SAVE THESE INSTRUCTIONS!

Section One: Install the Junction Box

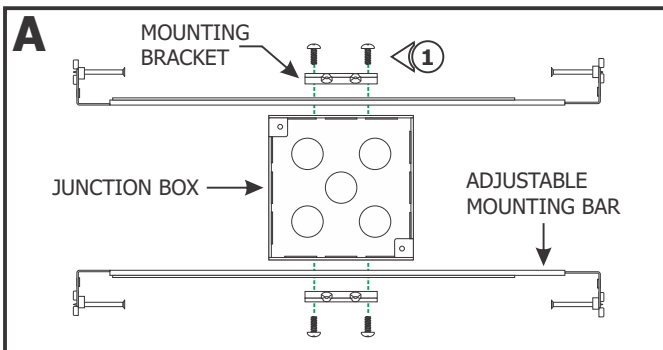

- 1:** Mount each adjustable mounting bar to one side of the junction box and secure them with the mounting brackets and two Phillips screws provided.

NOTE: Adjustable mounting bars mount to studs that are spaced 14.5" to 25" apart.

- 2:** Select the location between the two studs for the junction box to be mounted.
- 3:** Place the adjustable mounting bar tabs between the studs. Secure the adjustable bars to the studs with the #8 screws.
- 4:** Pinch anywhere on the inner edge of the mounting bars to lock in place.

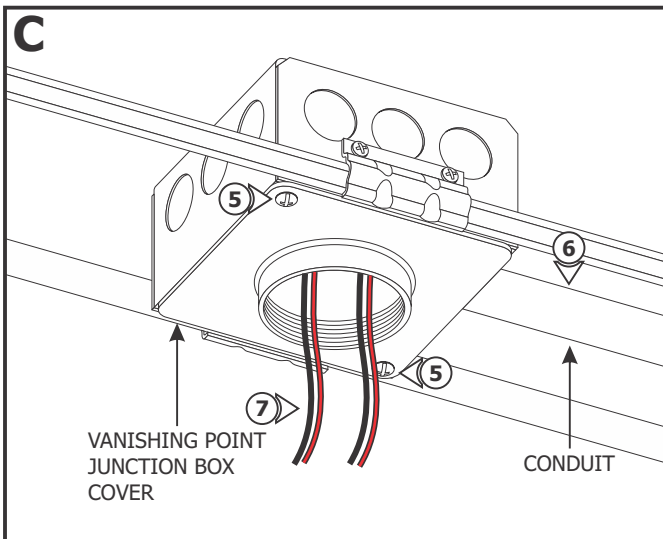
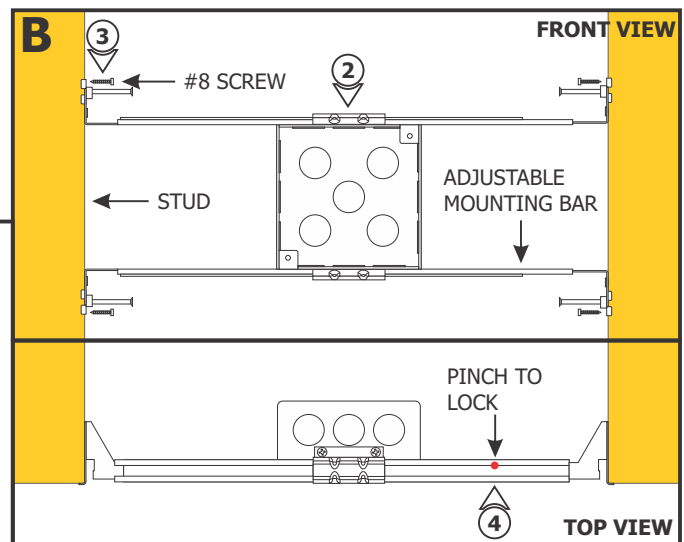

- 5:** Install the Vanishing Point junction box cover to the junction box using two #8-32 screws.

- 6:** Remove a knockout to install conduit(s) into the junction box. Install conduit(s) (if required by local electrical code).

- 7:** Run the low-voltage 24V wires coming from the remote power supplies to the junction box.

NOTE: Ensure remote power supply wires are present in the junction box. Refer to instructions provided with the power supply.

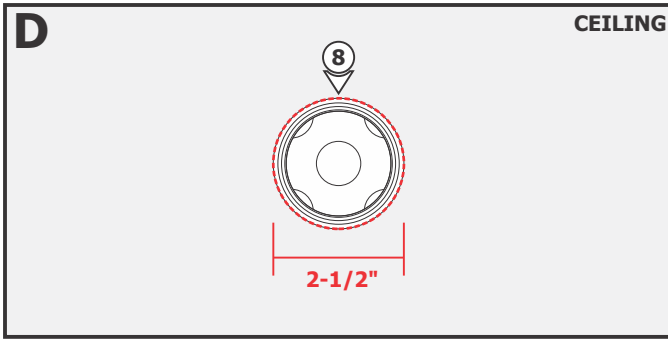

- 8:** Use a 2-1/2" hole saw to cut out the drywall section where the junction box opening is located.
- 9:** Install the drywall. If necessary, plaster and finish the drywall.

Section Two: Install the Plaster Plate

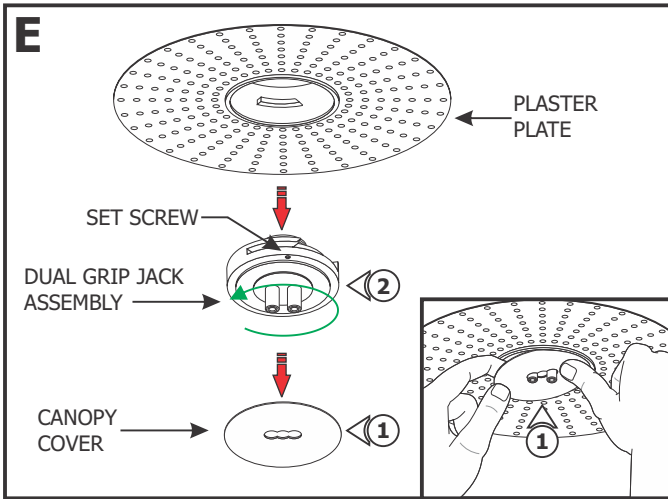

- 1:** Use fingers to push on the perimeter of the canopy cover until it slightly rocks and lift the cover to remove it from the assembly.
- 2:** Loosen (**Do Not Remove**) the #4-40 set screws on the Dual Grip Jack assembly using a 0.05" Allen wrench and rotate the Dual Grip Jack assembly counter clockwise to remove from the Plaster Plate.

- 3:** Screw the plaster plate clockwise into the junction box cover, ensuring the plate is tight.
- 4:** If the drywall is 5/8" thick, tighten the bottom #4-40 set screw inside the plaster plate using a 0.05" Allen wrench.
- 5:** If the drywall is 3/4" and thicker, tighten the top #4-40 set screw inside the plaster plate using a 0.05" Allen wrench.

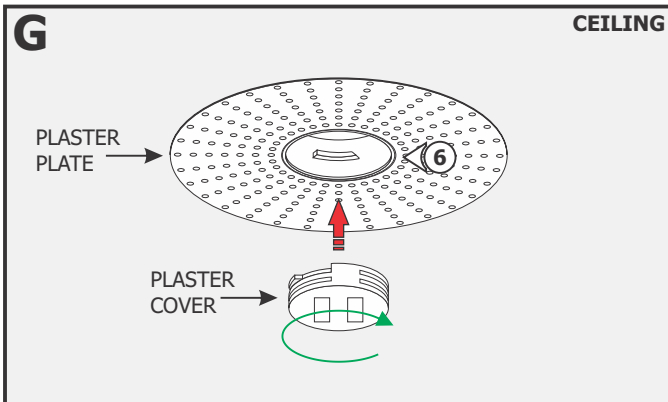
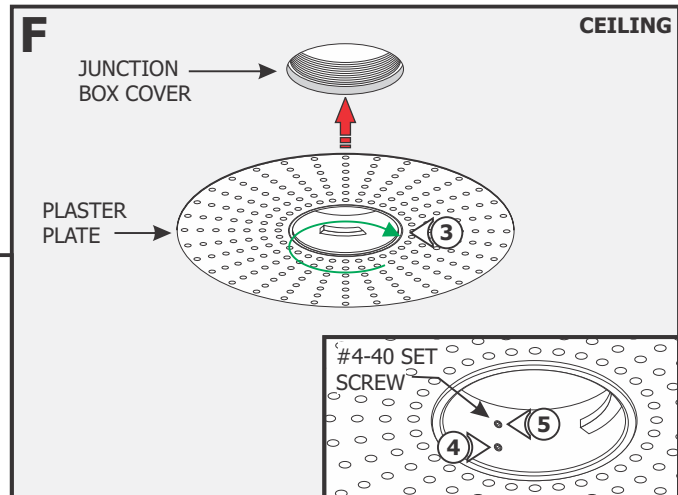

- 6:** Rotate the plaster cover clockwise into the plaster plate.
- 7:** Plaster, sand and paint the surface.

NOTE: For areas with lots of vibration, it is suggested to use Durabond to avoid cracking of plaster.

NOTE: **Do Not use premixed joint compound "Soft Mud."**
No use compuesto para juntas premezclado "Soft Mud."

NOTE: Recommended plaster method: 1st Coat - Durabond 45 with 8" Blade, 2nd Coat - Easy Sand 45 with 10" Blade, 3rd Coat with 12" Blade

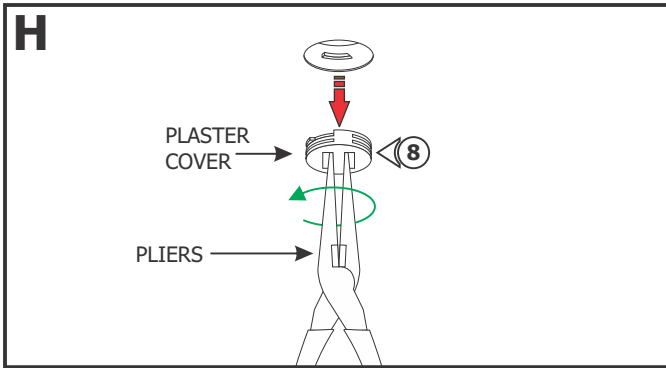

8: Use pliers to rotate the plaster cover counter clockwise and remove it. Clean the hole.

Section Three: Install the Fixture

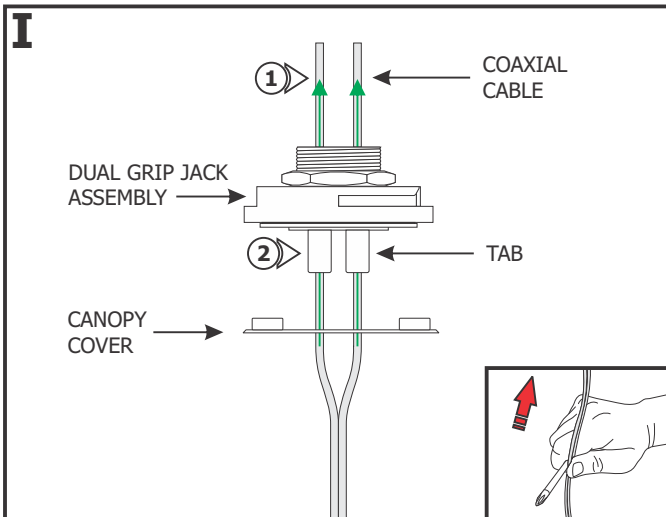

NOTE: If cable is curled or kinked, straighten by holding between the shaft of a screwdriver and thumb and pulling the cable through.

- 1:** Feed the fixture cables through the canopy cover and push the cables through the Dual Grip Jack assembly.
- 2:** Adjust the fixture height by pushing the grip jack tabs to slide the fixture up and down until the desired height is achieved. Release the tabs to lock the cable in place.
- 3:** Leave at least 6" of cable behind the Dual Grip Jack assembly.

 **NOTE:** Scan the QR Code to watch the video clip of the following steps or visit https://www.PureEdgeLighting.com/video_feed/installation_cxc_connector

- 4:** Use the 18AWG hole of the wire stripper to remove 1-3/8" of the outer insulation to expose the braided wire.
- 5:** Use the 18AWG hole of the wire stripper to remove 1" of the braided wire making sure not to nick the inner wire insulation.
- 6:** Use the 20AWG hole of the wire stripper to remove 1/8" of the inner insulated wire.

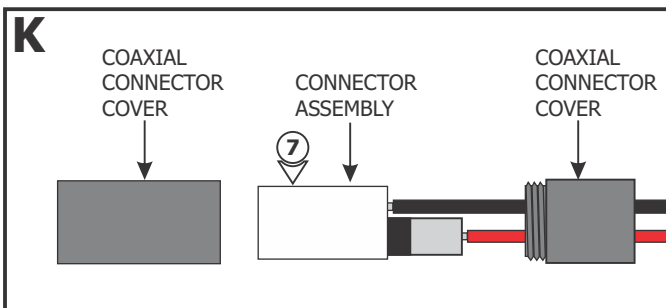
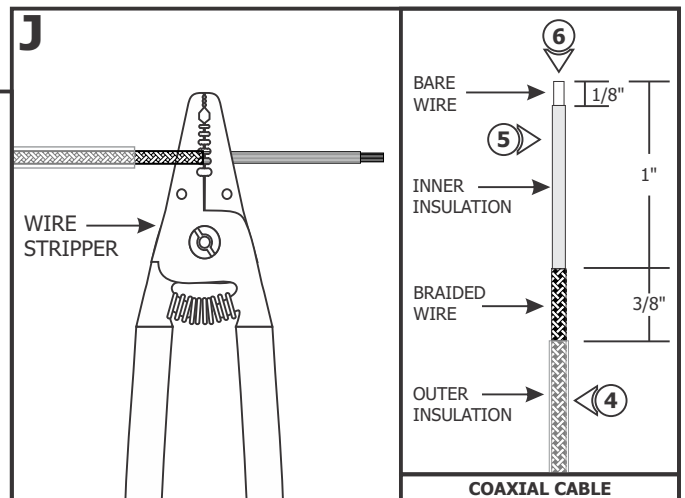

7: Unscrew the coaxial connector covers and remove from the connector assembly.

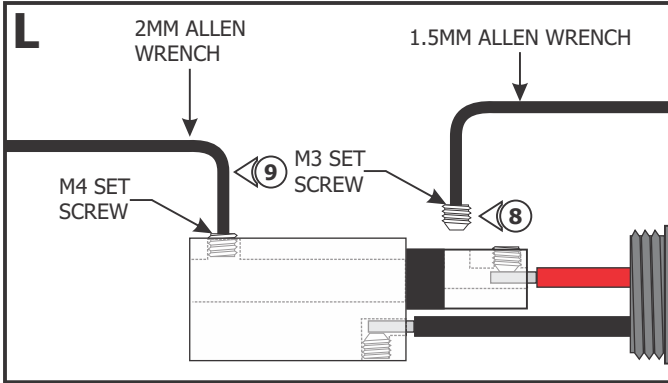

8: Using the provided 1.5mm Allen wrench, remove the M3 set screw from the coaxial connector assembly.

9: Using the provided 2mm Allen wrench to loosen (do not remove) the M4 set screw.

10: Slide the connector cover over the coaxial cable.

11: Place the ferrule over the 3/8" braided wire of the coaxial cable.

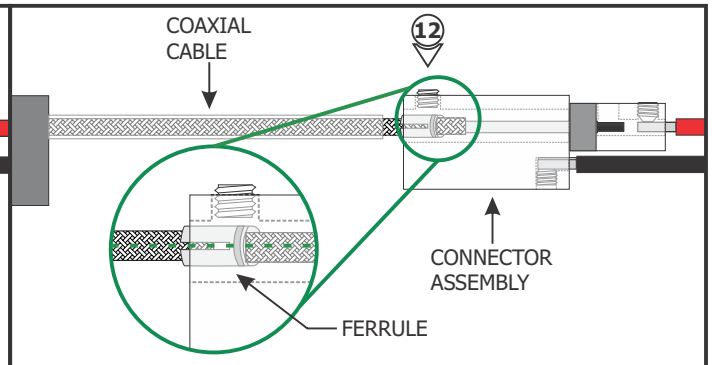
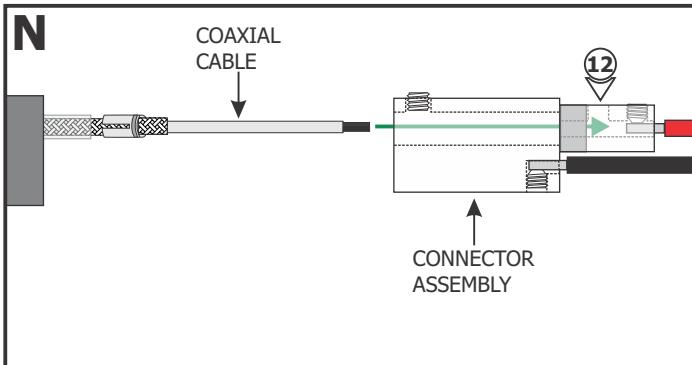
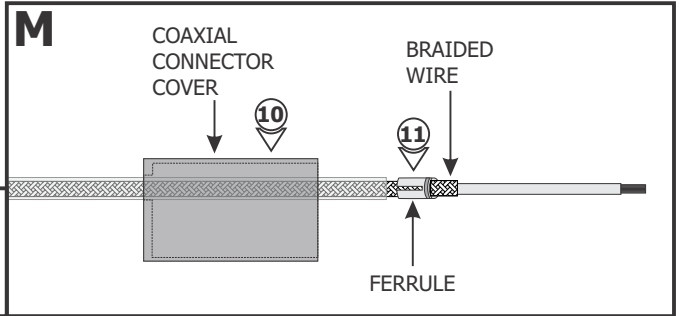

12: Insert the coaxial cable into the coaxial connector until the wires of the center conductor are visible through the M3 set screw hole.

NOTE: Ensure that the split in the ferrule is aligned 90° from the M4 set screw (see inset).

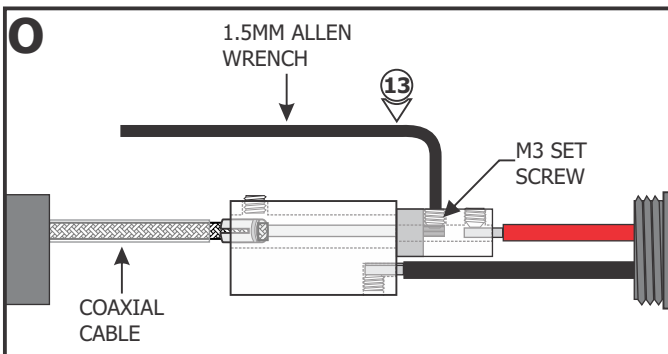

13: Use the provided 1.5mm Allen wrench to replace and securely tighten the M3 set screw.

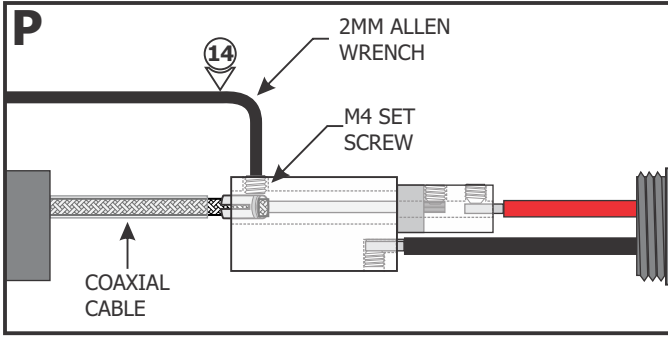

14: Use the provided 2mm Allen wrench to securely tighten the M4 set screw until it squeezes the wire ferrule tightly to the coaxial cable.

15: Replace the coaxial connector cover and tighten into place.
16: Repeat steps 4 through 15 for the other coaxial cable.

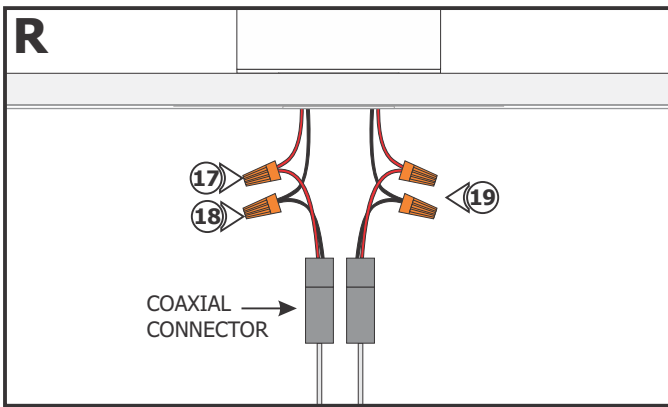
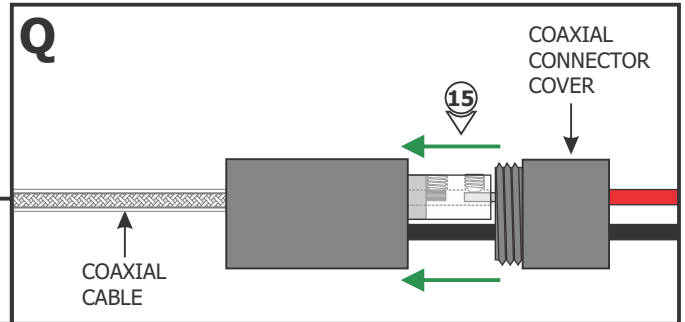

17: Connect the +24VDC power supply wire to the red coaxial connector wire using a wire nut.
18: Connect the -24VDC wire from the same power supply to the black wire from the same coaxial connector using a wire nut.
19: Repeat steps 17 and 18 for the other coaxial connector and power supply.

20: Place the coaxial connectors and wire nut connections inside the junction box.
21: Insert the Dual Grip Jack assembly into the opening and rotate clockwise to lock in place.
22: Tighten the #4-40 set screws using a 0.05" Allen wrench to secure in place.
NOTE: Test the fixture.

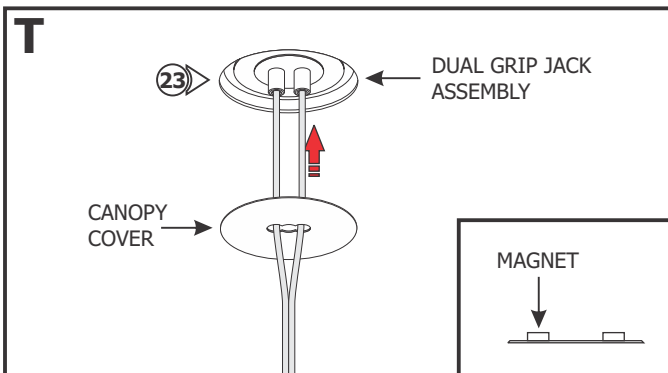
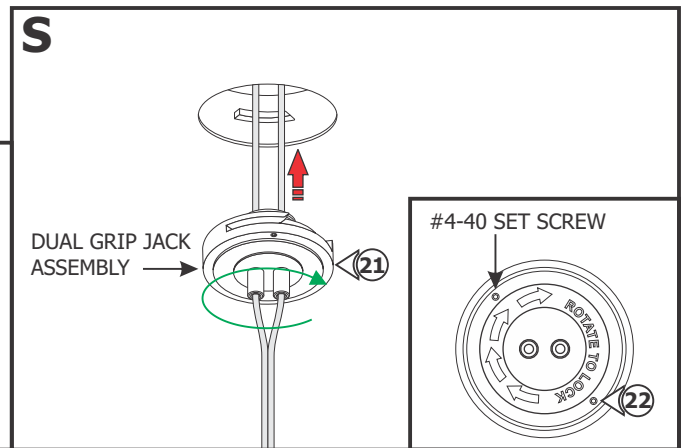

23: Place the canopy cover over the Dual Grip Jack assembly. The magnets on the back will keep the canopy cover in place.

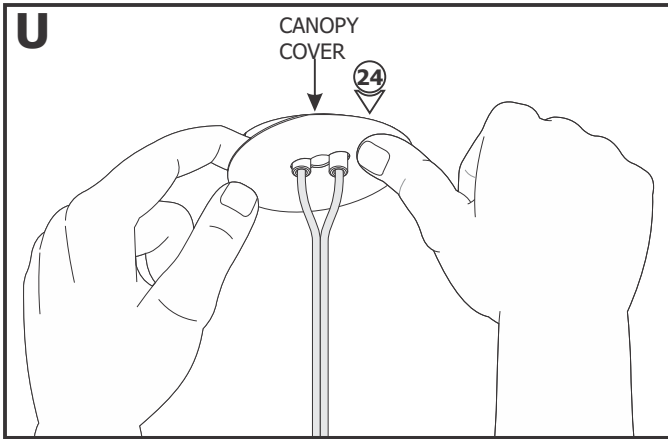

24: If necessary, use fingers to push on the perimeter of the canopy cover until it slightly rocks and lift the cover to remove it from the assembly.

NOTE: If using metal tools to apply plaster, be careful not to remove the magnetic canopy cover while plastering.

25: For no outline of the canopy, cover the Dual Grip Jack tab with contractor's tape. Plaster, sand and paint over the canopy cover and surface.

