



© 2016 Pure Lighting. All Rights Reserved.

Installation Instructions For TruLine 1.6A 24VDC

1718 W. Fullerton Ave
Chicago, IL 60614
Tel: 773-770-1196
Fax: 773-935-5613
www.purelighting.com
info@purelighting.com

IMPORTANT INFORMATION

- This fixture is wall or ceiling mount.
- This instruction shows a typical installation.
- **Consult the configuration notes on Page 1 before beginning any installation.**

SAVE THESE INSTRUCTIONS!

Section One: Basic Configuration Options

Horizontal Configuration

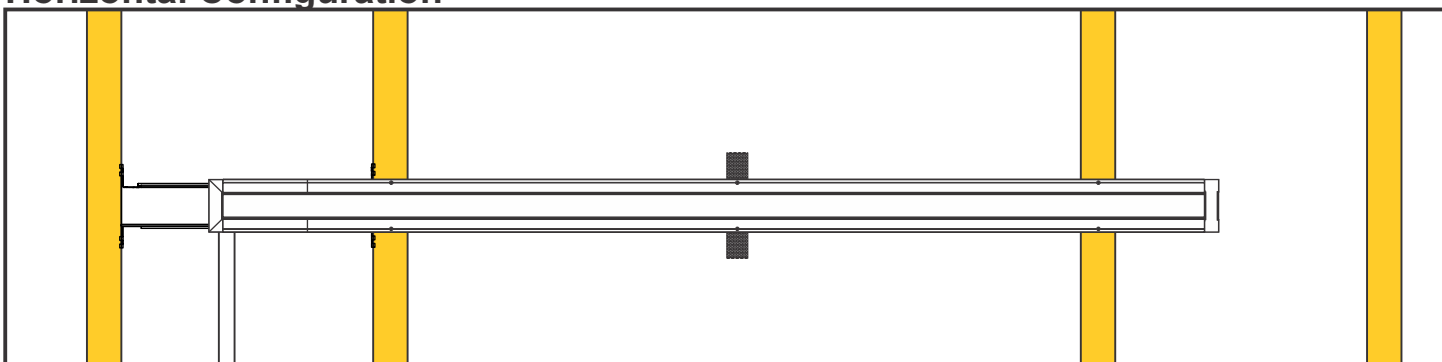

Horizontal installations are linear runs of channel beginning at a junction box and ending at a take-up box on a single surface. Runs can be up to 40' in length and the LED strip lays in the bottom of the channel.

Horizontal installations are typically installed perpendicular to wall studs or ceiling joists. Where no stud/joist is present (or in a remodel installation) a mounting strap may be used to secure the channel to the drywall.

Vertical Configuration

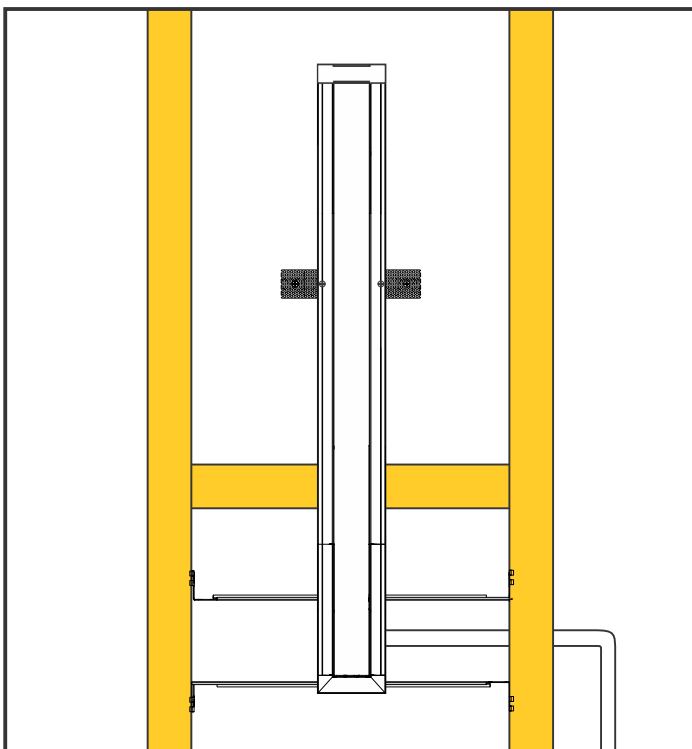

Vertical installations are linear runs of channel beginning at a junction box and ending at a take-up box on a single surface. Runs can be up to 40' in length and the LED strip lays in the bottom of the channel.

Vertical installations are typically installed between wall studs or ceiling joists. Cross-braced stud sections or mounting straps are suggested to provide additional support every 32".

Room-Wrapping Configuration

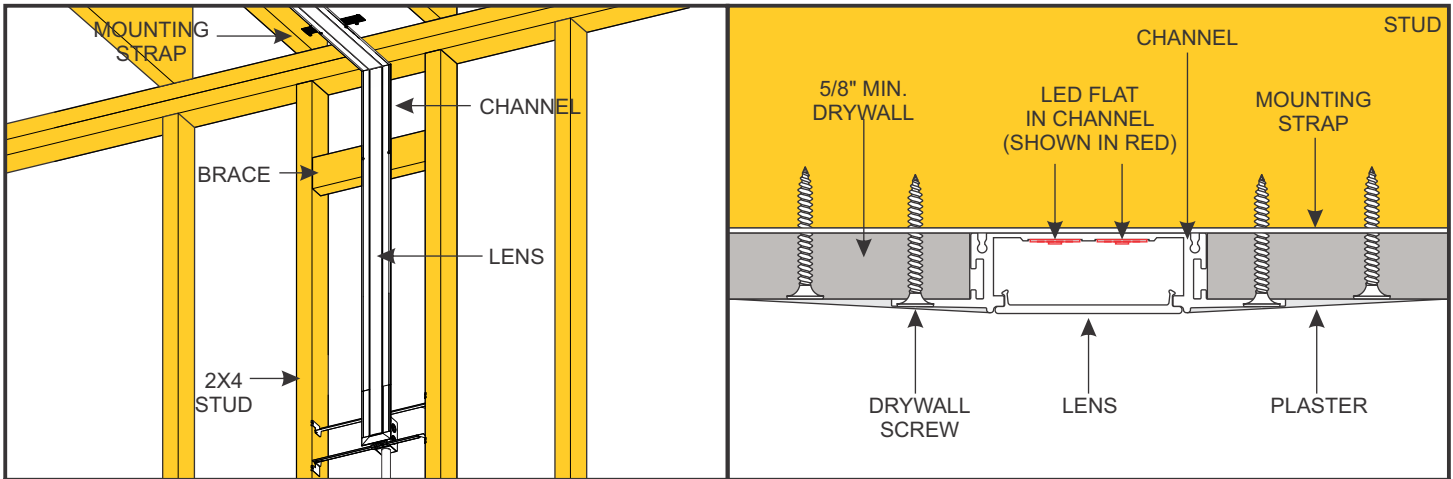

Room-wrapping configurations are used for installations that join runs of **TruLine 1.6** on multiple planes (like a ceiling and a wall) using miter-cut linear sections of channel.

For room-wrapping installations, the LED strip will be installed in the bottom of the channel.

Zig Zag Configuration

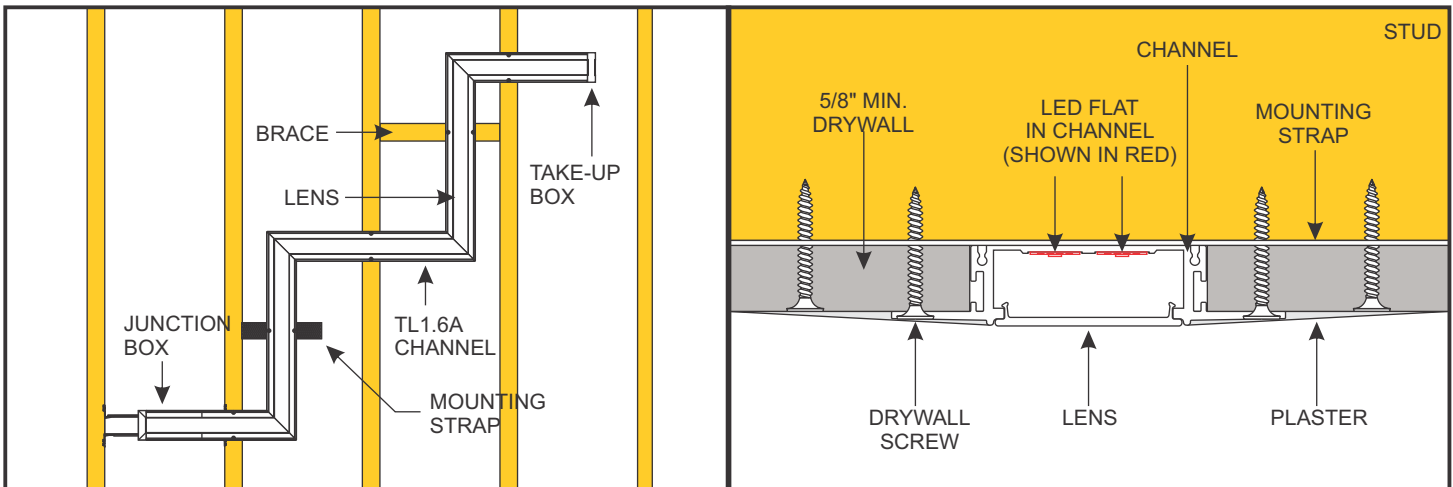

Zig Zag configurations are used for installations that join runs of **TruLine .5A** on a single plane (like a ceiling or a wall) using miter-cut sections of channel.

For Zig Zag installations, the LED strip will be installed in the side of the channel to allow the strip to follow the channel corners.

Section Two: Standard Horizontal Installation

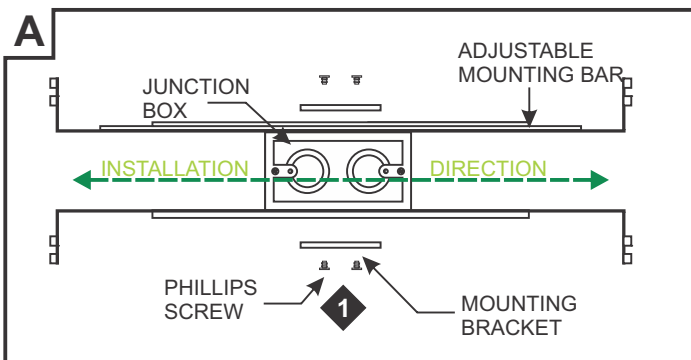

1: Mount each adjustable mounting bar to one side of the junction box and secure them with the mounting brackets and two Phillips screws provided.

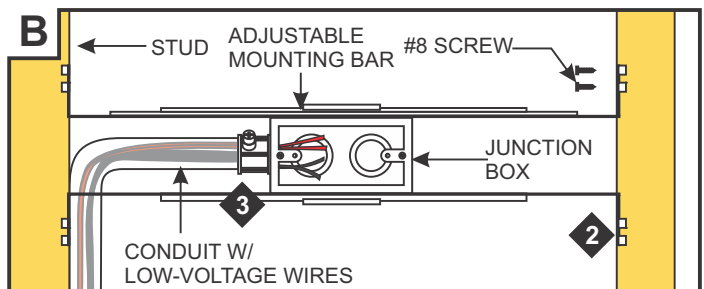

NOTE: The adjustable mounting bars mount to studs that are spaced 13" to 24" apart.

2: Place the lips on the adjustable mounting bars against the studs. Secure the adjustable bars to the studs with the eight #8 screws.

3: Install conduit (if required by local electrical code) and run low-voltage power wires to the junction box.

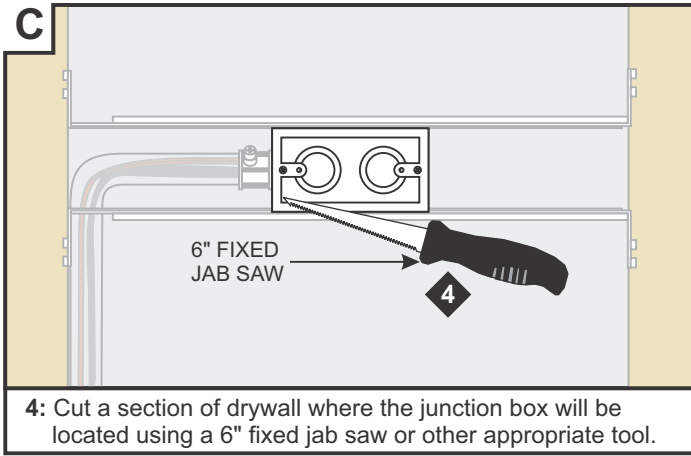

4: Cut a section of drywall where the junction box will be located using a 6" fixed jab saw or other appropriate tool.

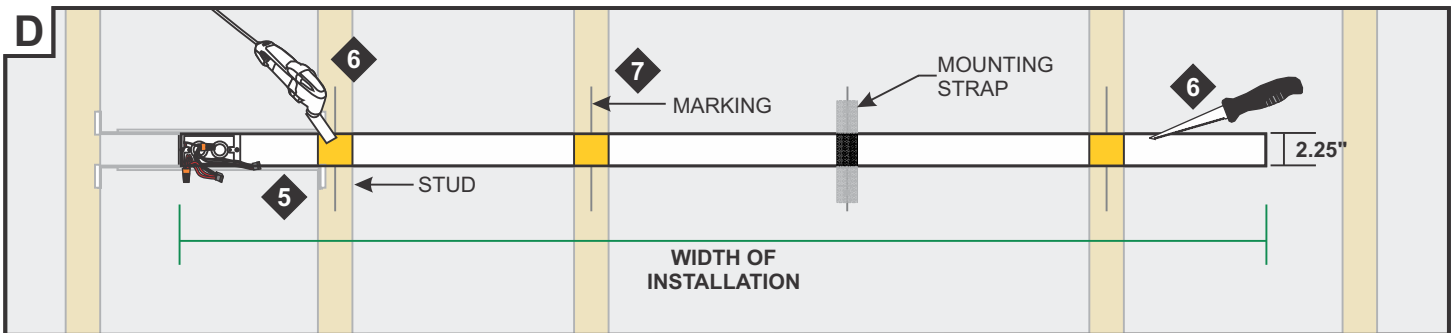

5: Mark the area where the channel will be located on the drywall using the junction box opening as a guide (MIN 2.25").

6: Cut out the marked area using a "Dremel Multi-Max" or a 6" Fixed Jab Saw.

7: Mark the location of the studs to the drywall for future reference.

NOTE: To install channel in a wall without standard-spaced studs, install perforated mounting straps every 32" behind drywall and secure using two drywall screws. Mark the location of any mounting straps to the drywall.

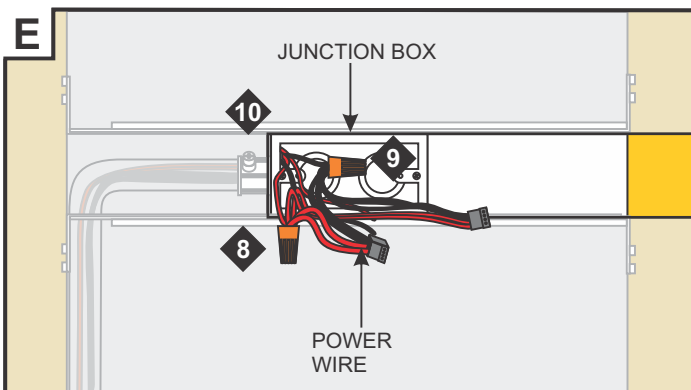

NOTE: Remote power supply wires must be present in junction box. Refer to instructions provided with power supply.

8: Connect the red power supply (24VDC+) wires to each red power wire with a wire nut inside the junction box.

9: Connect the black power supply (24VDC-) wires to each black power wire with a wire nut inside the junction box.

10: Place the wire nut connections inside junction box.

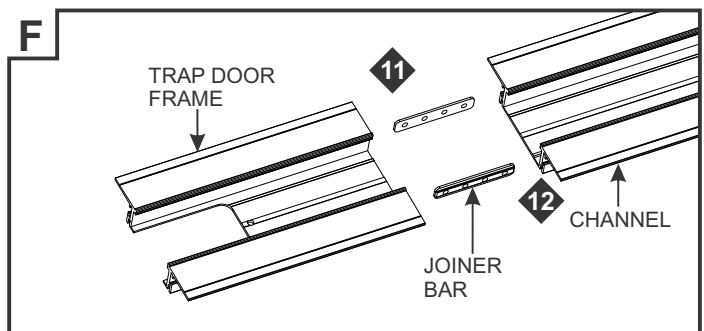

11: Insert the joiner bars halfway into the channel trap door frame. Tighten the two M3 set screws on each joiner bar with a 1.5mm Allen wrench.

12: Slide the other section of channel onto the joining bars and tighten the remaining M3 set screws with a 1.5mm Allen wrench.

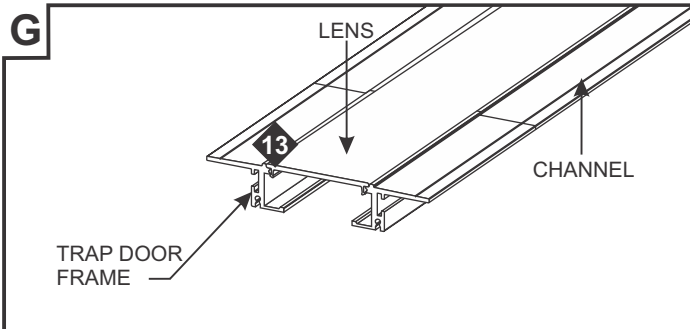

13: Snap the lens into the assembled trap door frame and channel **BEFORE** cutting to length. This ensures a proper fit after installation.

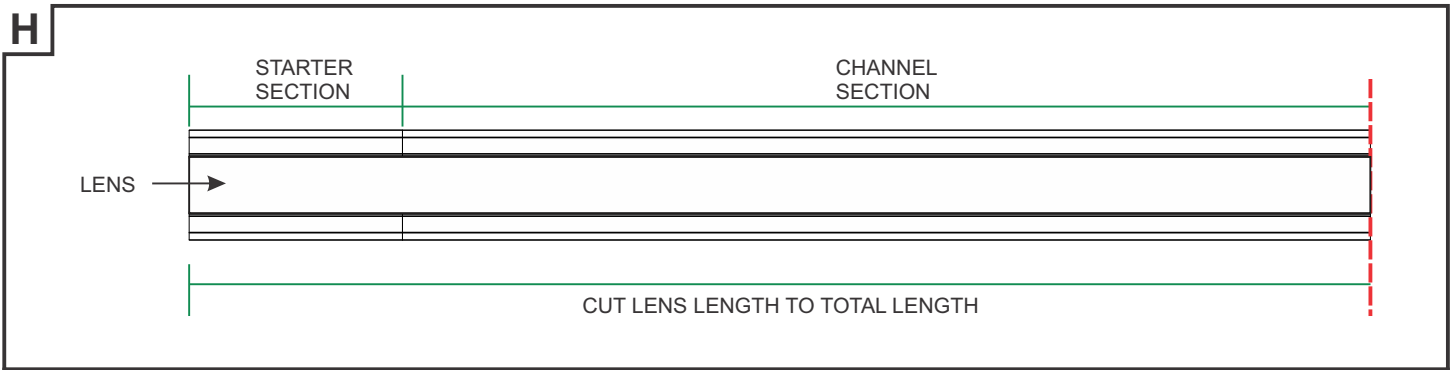

NOTE: If cutting channel to length, ensure that the lens is also cut to match the total length of the installation.

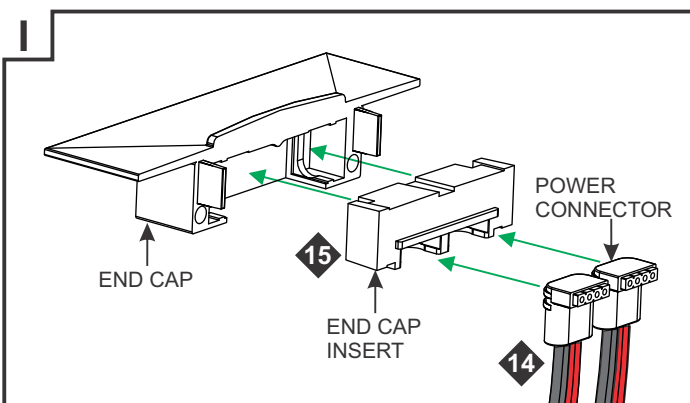

14: Place both power connector into the end cap insert.
15: Slide the assembled end cap insert and power connectors into the end cap.

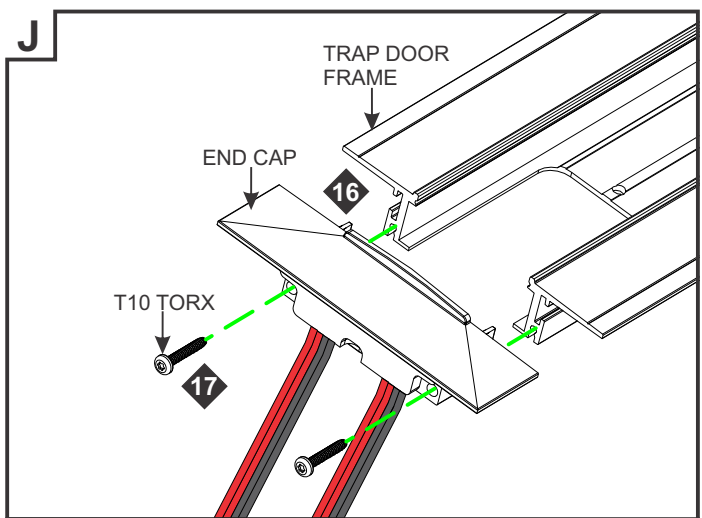

16: Insert the #4-40 Torx screws through the end cap holes and thread into the TruLine 1.6A channel.
17: Tighten the end cap to the channel using the provided T10 screwdriver.

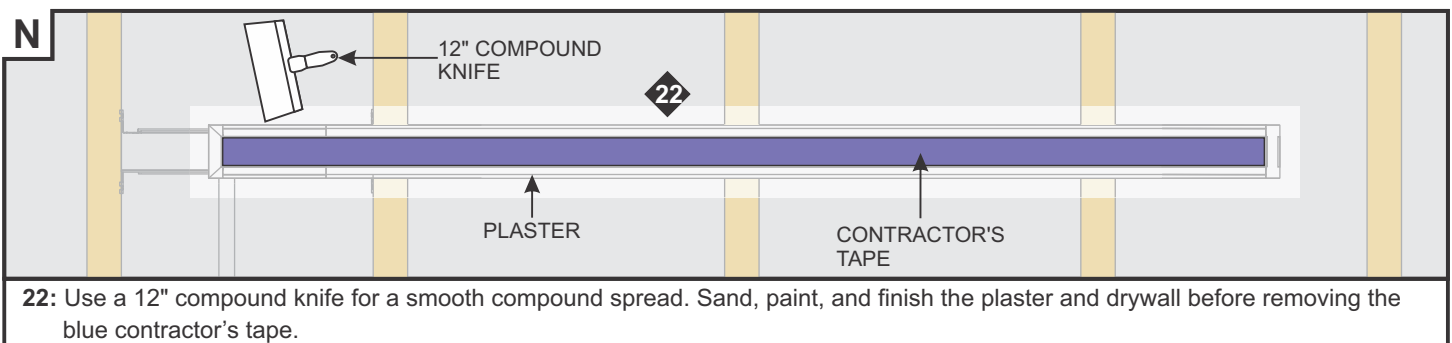
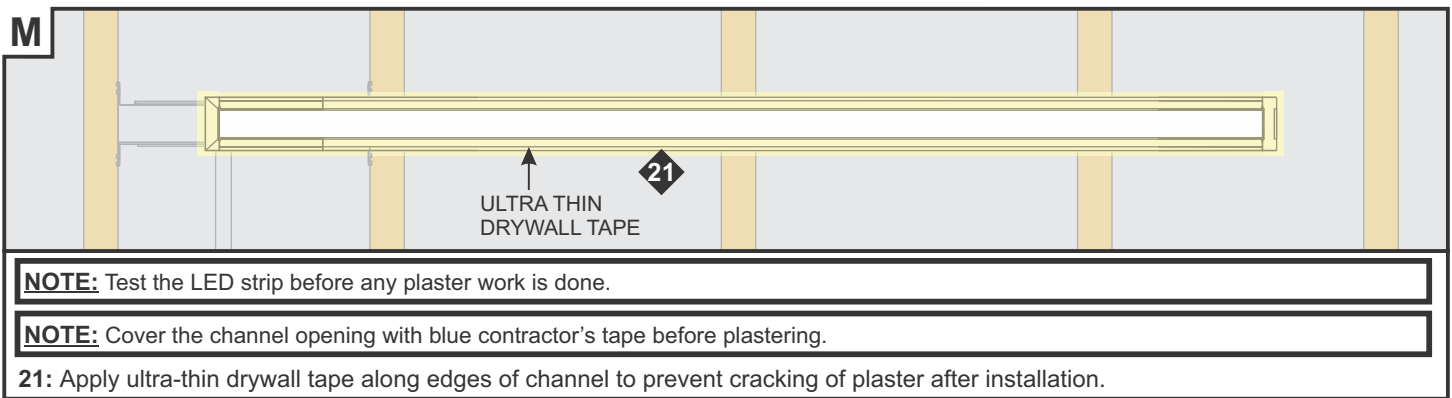
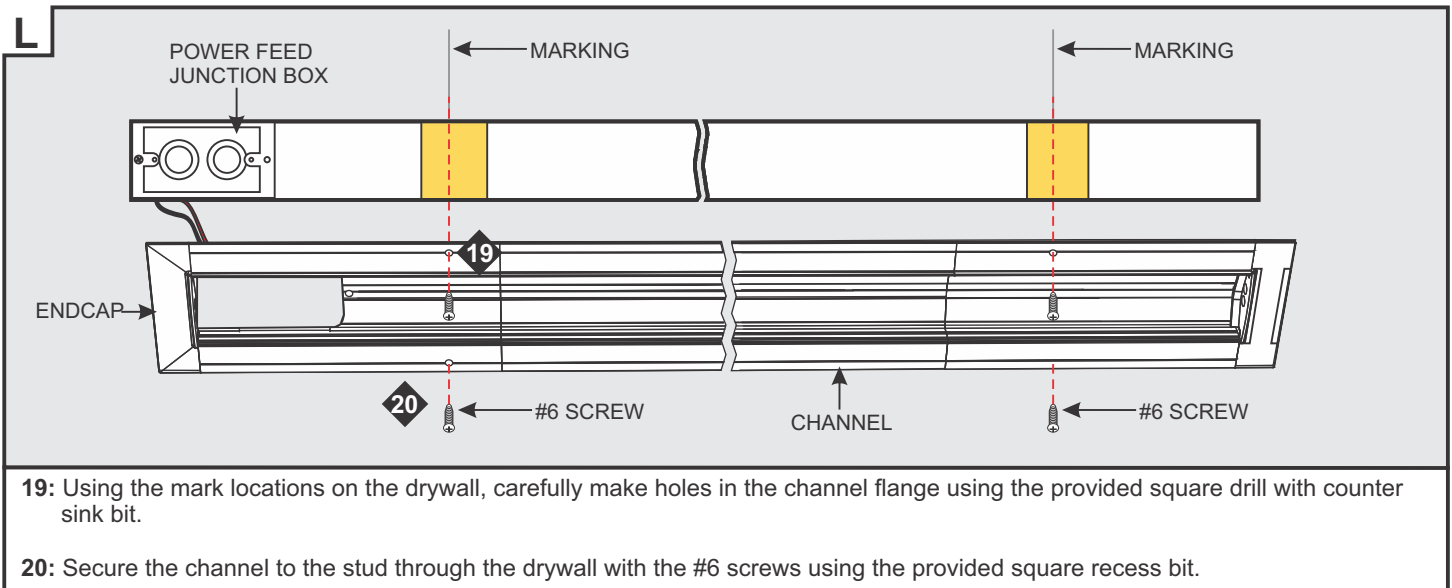
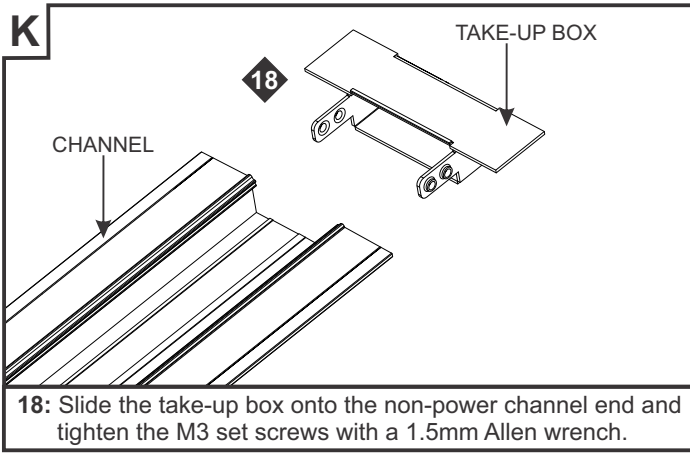

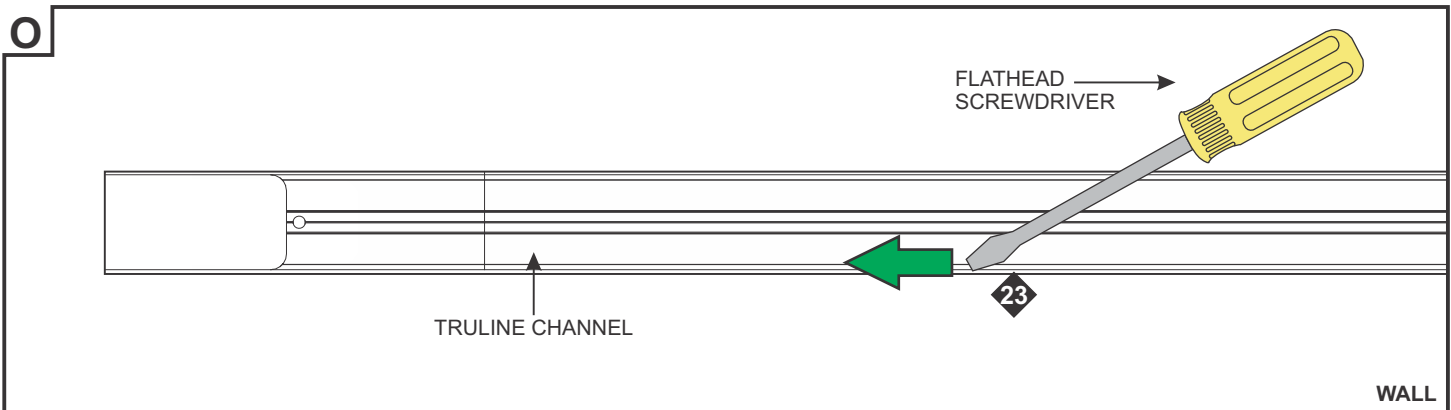

23: Carefully use a flathead screwdriver to remove excess drywall from the internal bevel/edge.

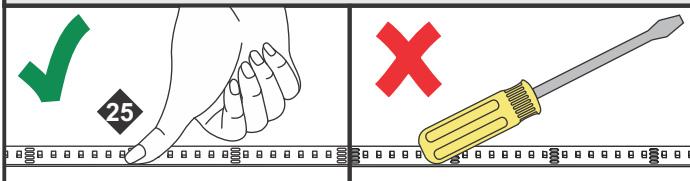
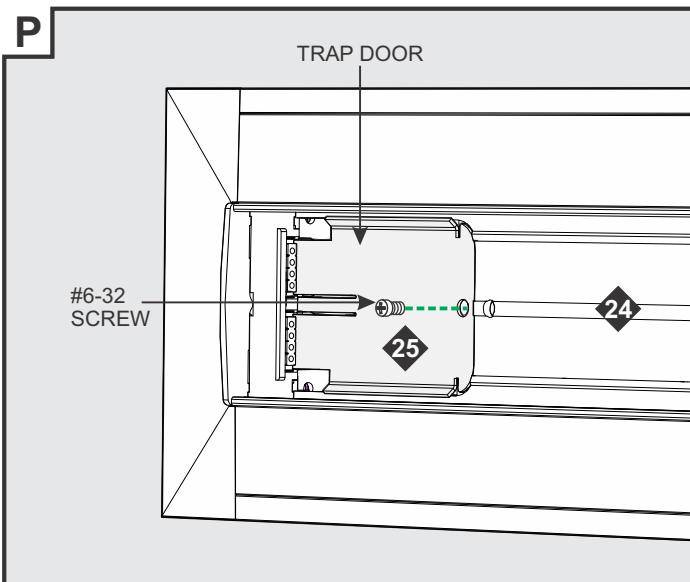

24: Remove the blue contractor's tape from the inside of the channel. Clean the channel surface with alcohol to remove any dust or debris before continuing.

25: Attach the trap door to the junction box using the #6-32 screw.

NOTE: If installation requires RGB, RGB+W, or Tunable White, refer to wiring diagrams on pages 19-21.

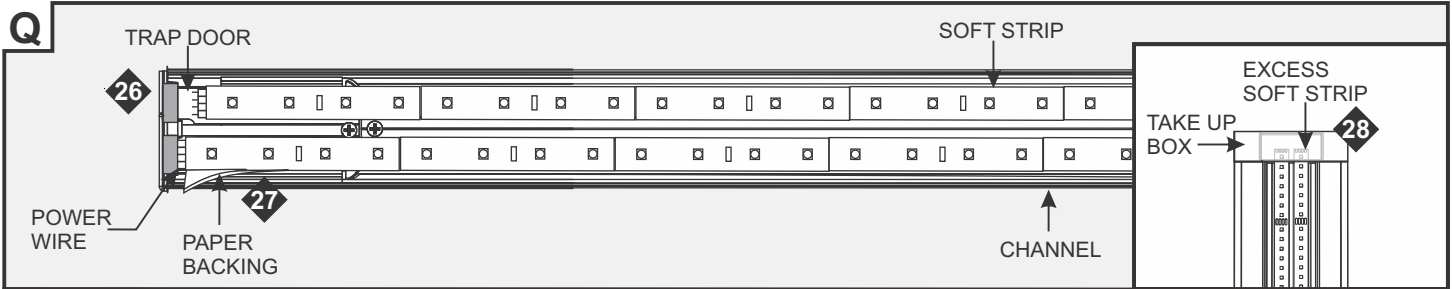

- 26:** Line up the red wire side of the power connector with the “+24VDC” marking on the Soft Strip. Push the male connector of the Soft Strip into the female connector of the power cables.
- 27:** Carefully remove the backing from the LED soft strip, making sure not to remove the tape from the soft strip. Firmly press down the adhesive portion of the soft strip onto the channel surface while removing the rest of the backing, making sure there are no air bubbles that can cause surface irregularities.
- 28:** If required, trim the soft strip on the dashed cuttable section, place the excess soft strip inside the take up box (see inset). Ensure the entire length of the channel is covered with Soft Strip to avoid unlit areas.

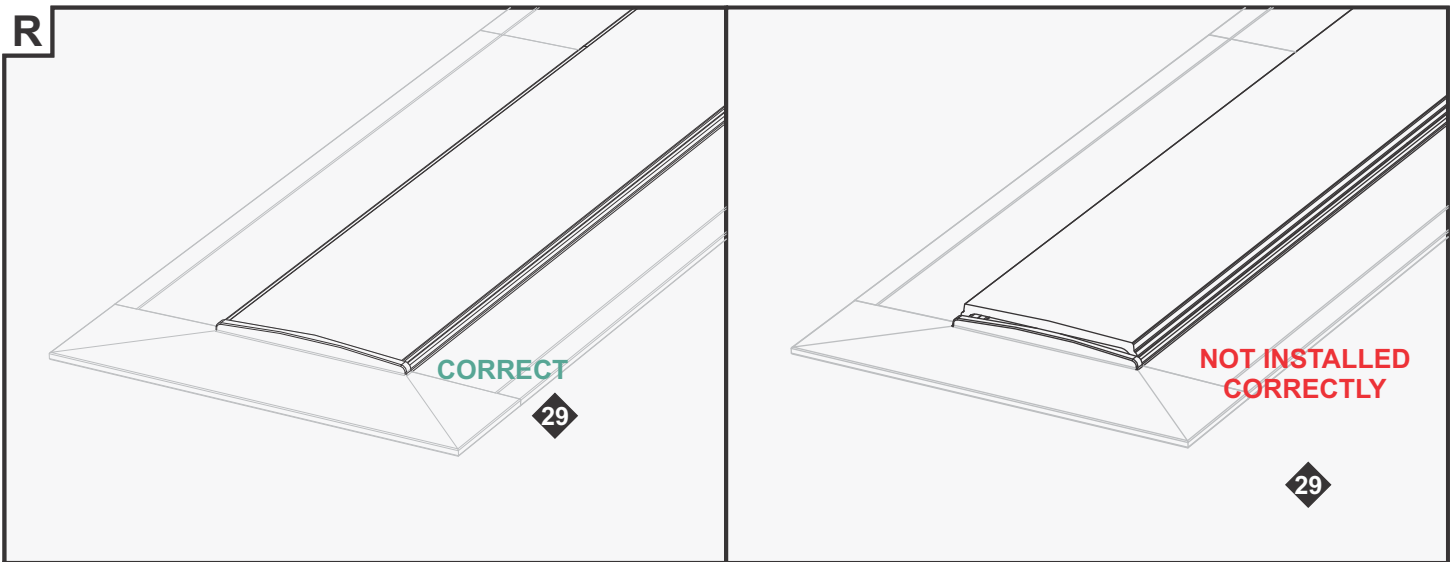

29: Snap the lens back onto the channel. Ensure lens is fully seated.

Section Three: Vertical Installation

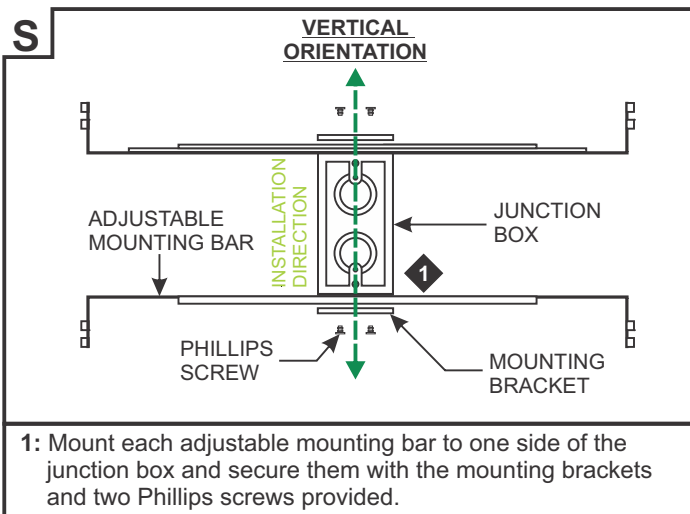

- 1:** Mount each adjustable mounting bar to one side of the junction box and secure them with the mounting brackets and two Phillips screws provided.

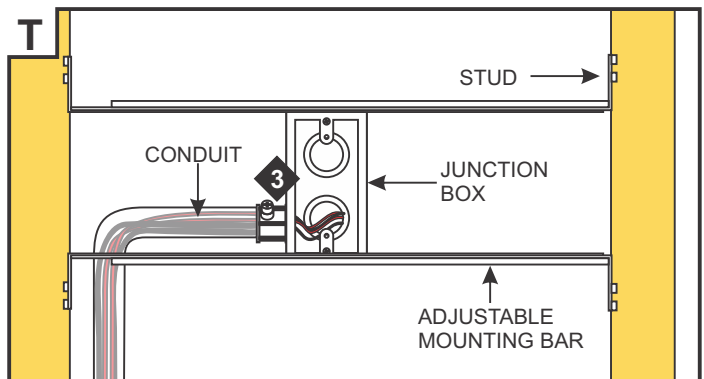

- 2:** Remove a knockout to install the power line conduit (if required by local electrical code).
- 3:** Install the conduit and run the low voltage 24VDC power wires coming from the remote power supply to the junction box.
- 4:** Refer to the instruction provided with the power supply along with the wiring diagram for proper wiring.

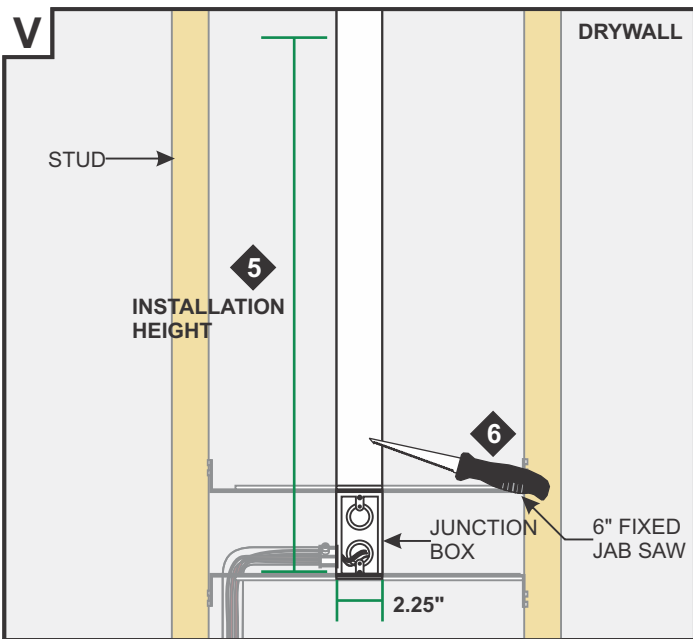
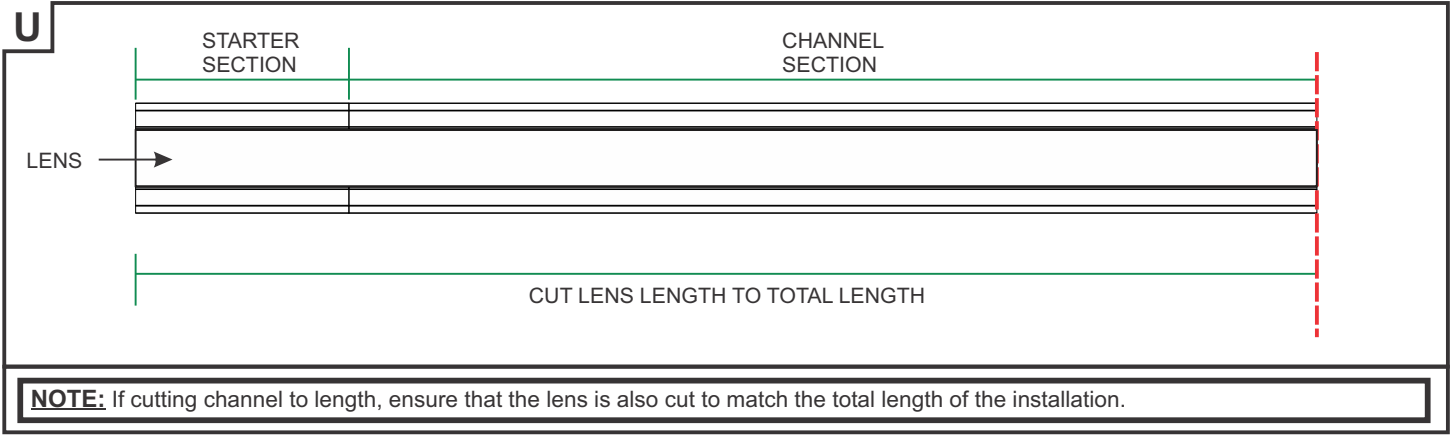

- 5: Mark the area where the channel will be located on the drywall.
- 6: Cut out the marked area using appropriate tools.
- 7: Mark the location of the studs on the drywall for future reference.

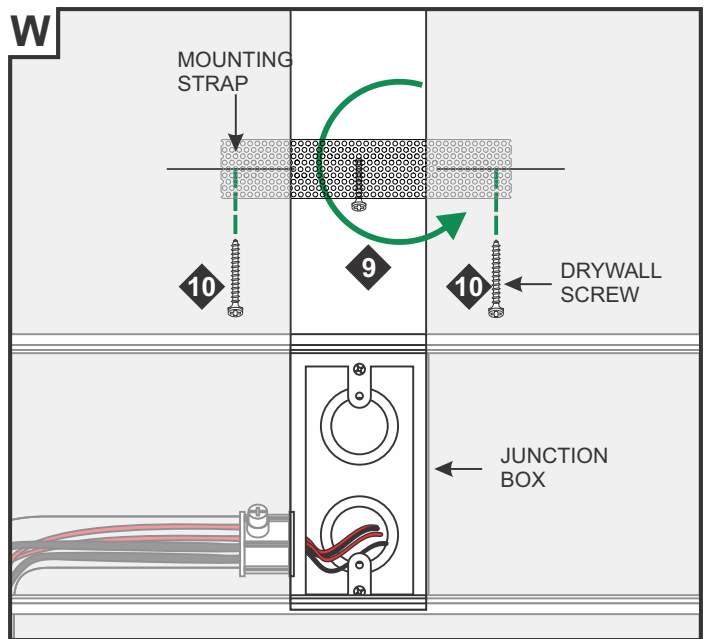

- 8: Install mounting straps behind the drywall (suggested spacing is every 32") by threading a drywall screw into the perforated material.
- 9: Place the mounting strap behind the cut drywall and rotate into place using the drywall screw as a handle.
- 10: Secure the mounting strap to the drywall using two drywall screws. Mark the location on the drywall.

NOTE: Complete mounting, plastering, painting, and LED strip installation by following Steps 14 through 29 in Section One.

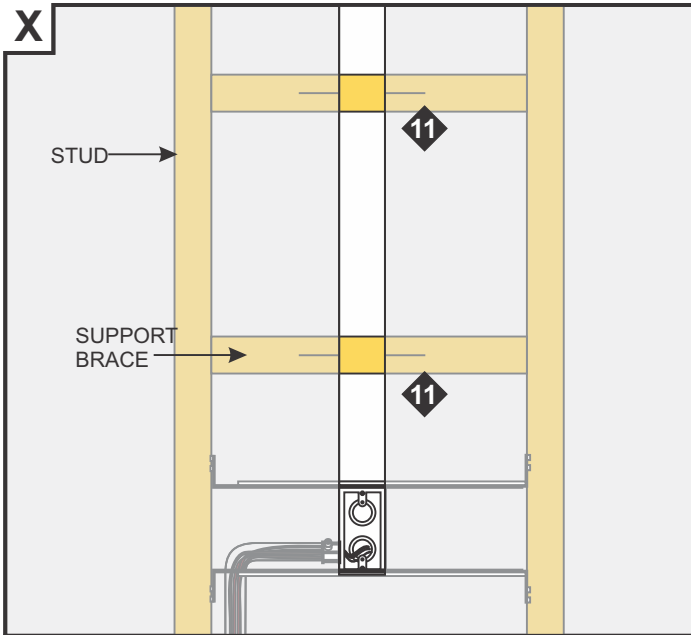

ALTERNATE VERTICAL INSTALLATION OPTION:
 11: Install 2x4 support braces (suggested spacing is every 32") before installing and finishing drywall.

Section Four: Room-Wrapping Configuration

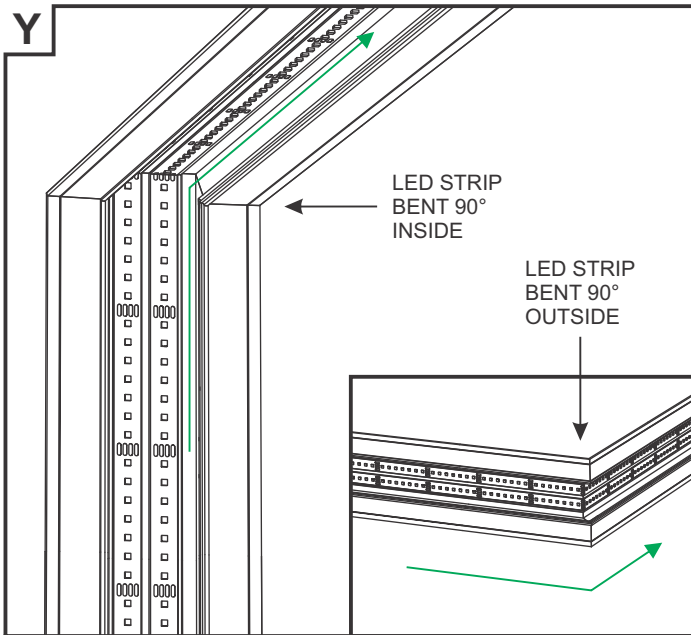

INSTALLATION NOTES
 Room-wrapping installations use LED strip bent 90° for inside or outside corner configurations. Channel sections will be miter cut on-site.

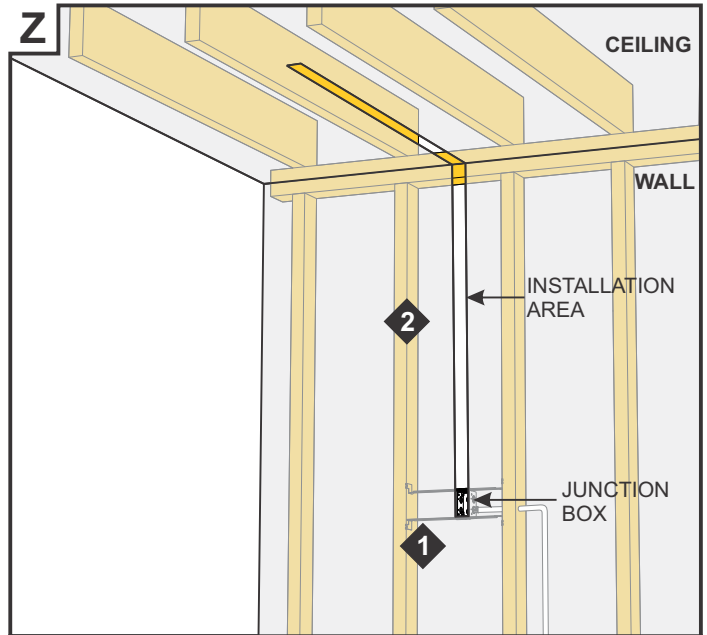

1: Install junction box and low-voltage power.
 2: Measure and mark installation length. Cut out marked areas using appropriate tools.

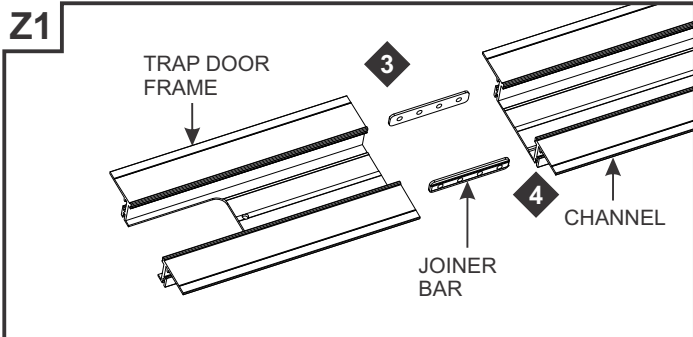

3: Insert the joiner bars halfway into the channel trap door frame. Tighten the two M3 set screws on each joiner bar with a 1.5mm Allen wrench.

4: Slide the other section of channel onto the joining bars and tighten the remaining set screws.

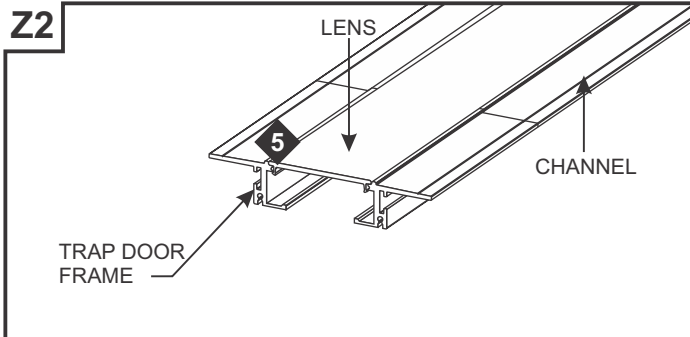

5: Snap the lens into the assembled channel **BEFORE** marking and cutting. This ensures a good fit when installed.

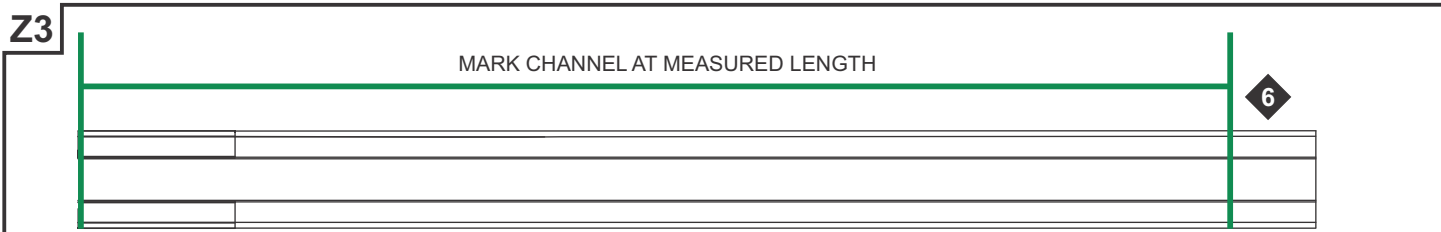

6: Mark the assembled channel and lens lengths using the measurements taken in Steps 6 and 7.

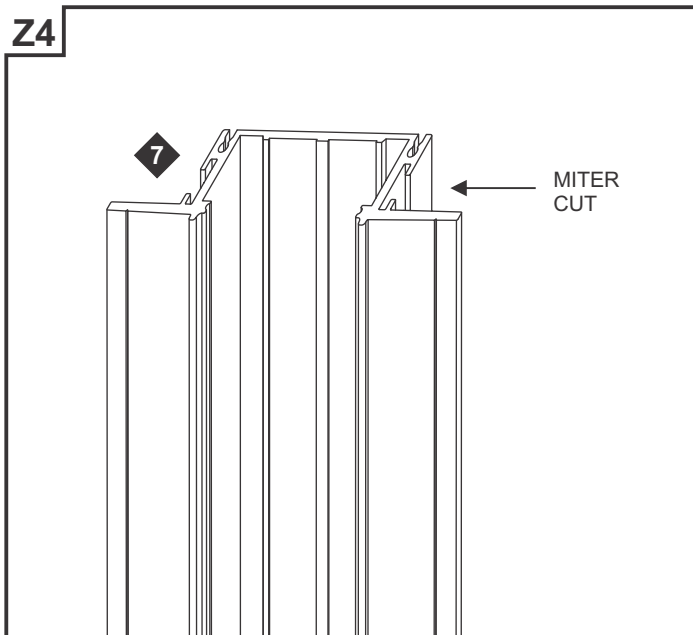

7: Miter cut each section of assembled channel and lens to match the corner angle. In a 90° corner installation as shown, each channel section is cut at a 45° angle to form a complete corner.

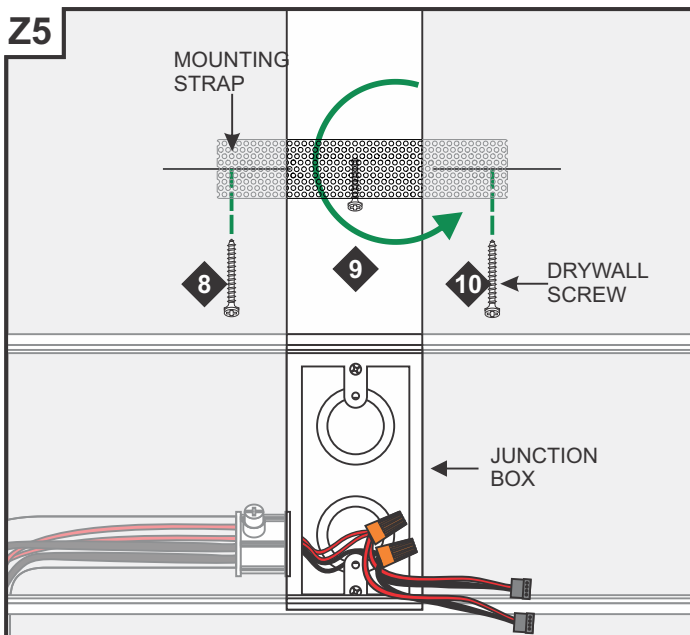

NOTE: Remote power supply wires must be present in junction box. Refer to instructions provided with power supply.

8: Install mounting straps behind the drywall (suggested spacing is every 32") by threading a drywall screw into the perforated material.

9: Place the mounting strap behind the cut drywall and rotate into place using the drywall screw as a handle.

10: Secure the mounting strap to the drywall using two drywall screws. Mark the location on the drywall.

Z6

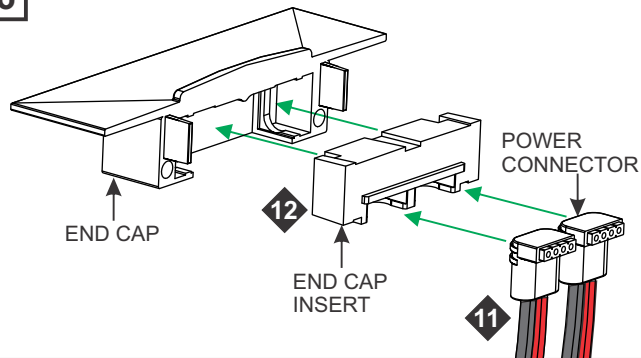

- 11: Place both power connectors into the end cap insert.
- 12: Slide the assembled end cap insert and power connectors into the end cap.

Z7

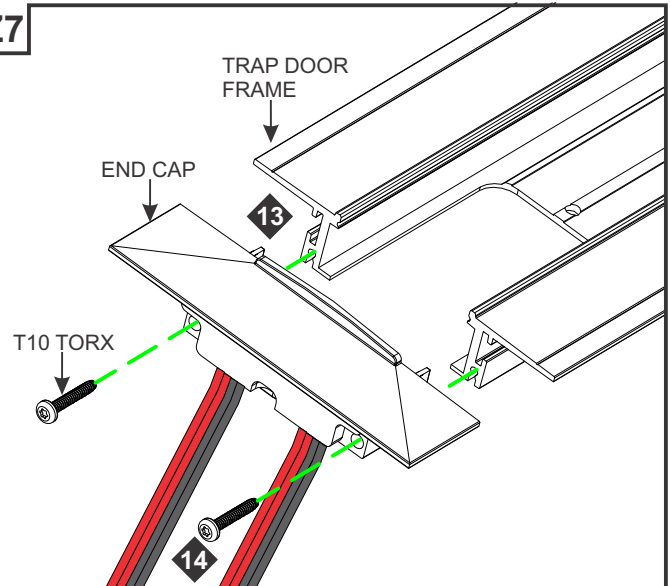

- 13: Insert the #4-40 Torx screws through the end cap holes and thread into the TruLine 1.6A channel.
- 14: Tighten the end cap to the channel using the provided T10 Torx screwdriver.

NOTE: Refer to page 5 Step 18 to install the take up box to the non power channel end.

Z8

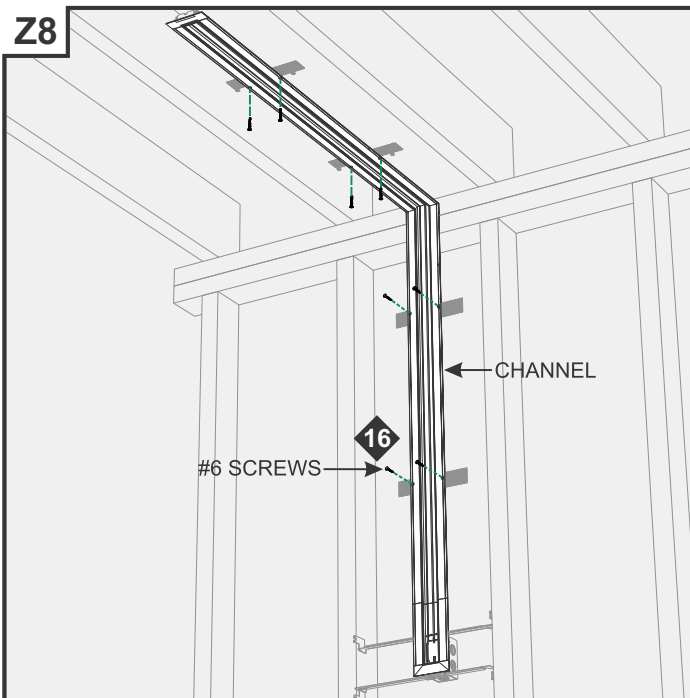

- 15: Using the marked locations on the drywall, carefully make holes in the channel flange using the provided square drill with counter sink bit.
- 16: Secure the channel to the studs/mounting straps through the drywall with the #6 screws using the provided square recess bit.

Z9

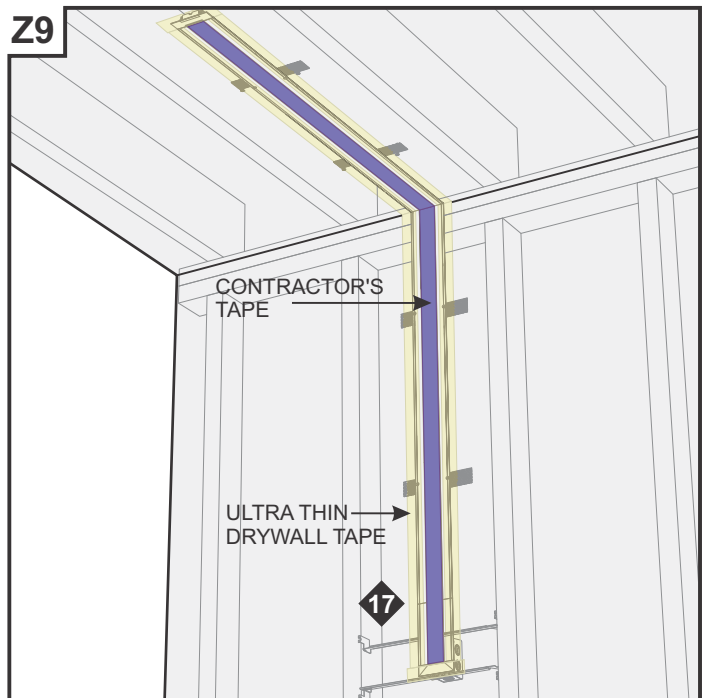

NOTE: Test the LED strip before any plaster work is done.

NOTE: Cover the channel opening with blue contractor's tape before plastering.

- 17: Apply ultra-thin drywall tape along edges of channel to prevent cracking of plaster after installation.

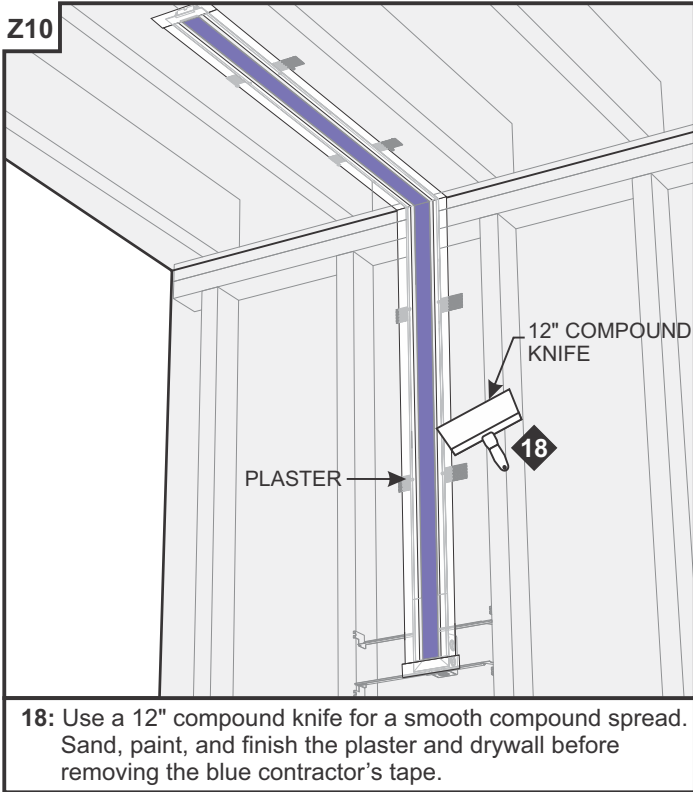

18: Use a 12" compound knife for a smooth compound spread. Sand, paint, and finish the plaster and drywall before removing the blue contractor's tape.

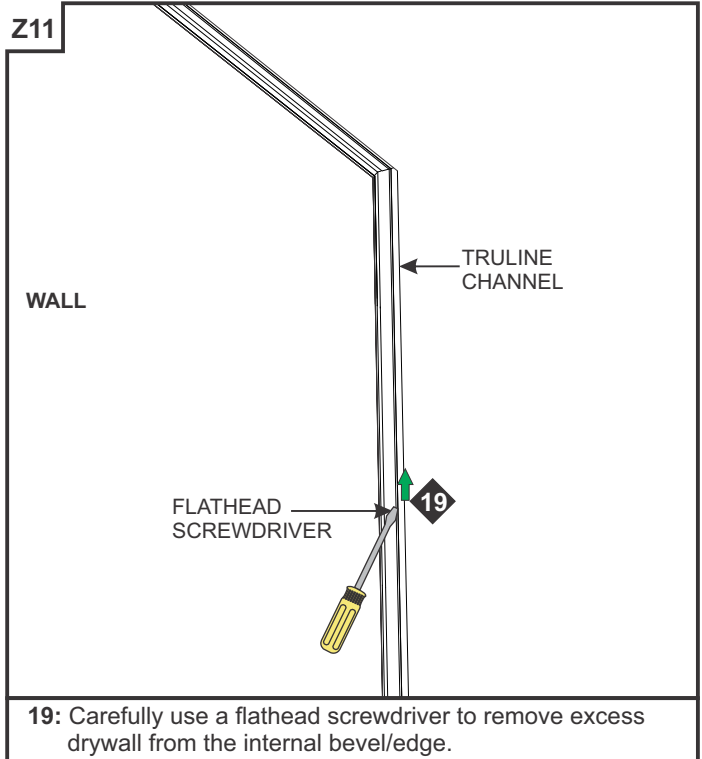

19: Carefully use a flathead screwdriver to remove excess drywall from the internal bevel/edge.

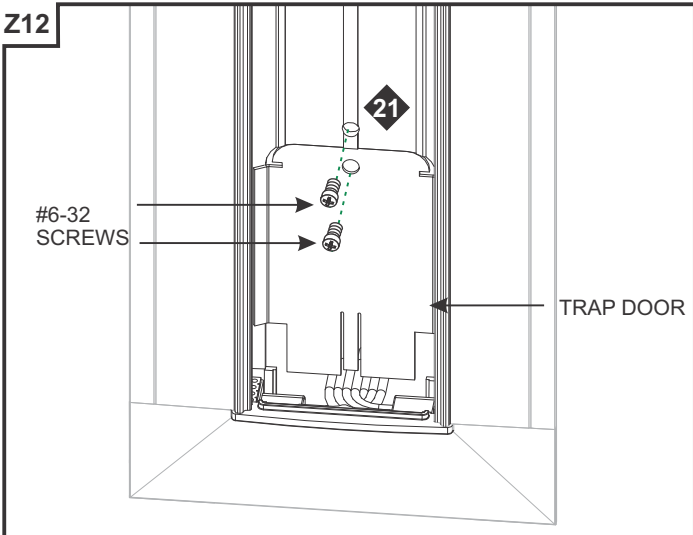

20: Remove the blue contractor's tape from the inside of the channel. Clean the channel surface with alcohol to remove any dust or debris before continuing.

21: Attach the trap door and frame to the junction box using the #6-32 screws.

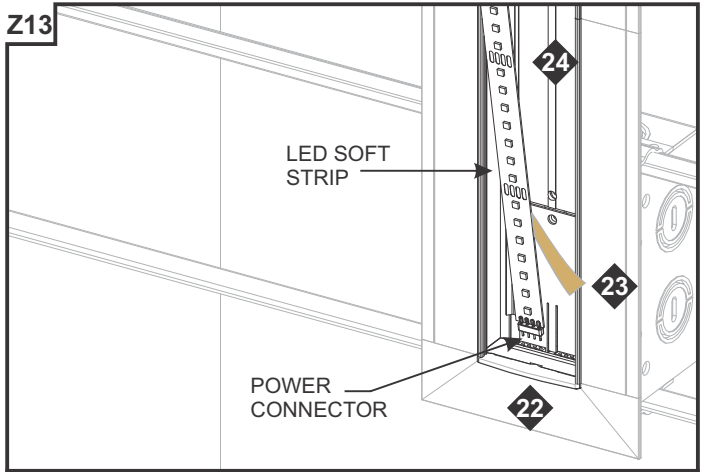

NOTE: If installation requires RGB, RGB+W, or Tunable White, refer to wiring diagrams on pages 19-21.

22: Line up the red wire side of the power connector with the "+24VDC" marking on the Soft Strip. Push the male connector of the Soft Strip into the female connector of the power cables.

23: Carefully remove the backing from the LED soft strip, making sure not to remove the tape from the soft strip.

24: Firmly press down the adhesive portion of the soft strip onto the channel surface while removing the rest of the backing, making sure there are no air bubbles that can cause surface irregularities.

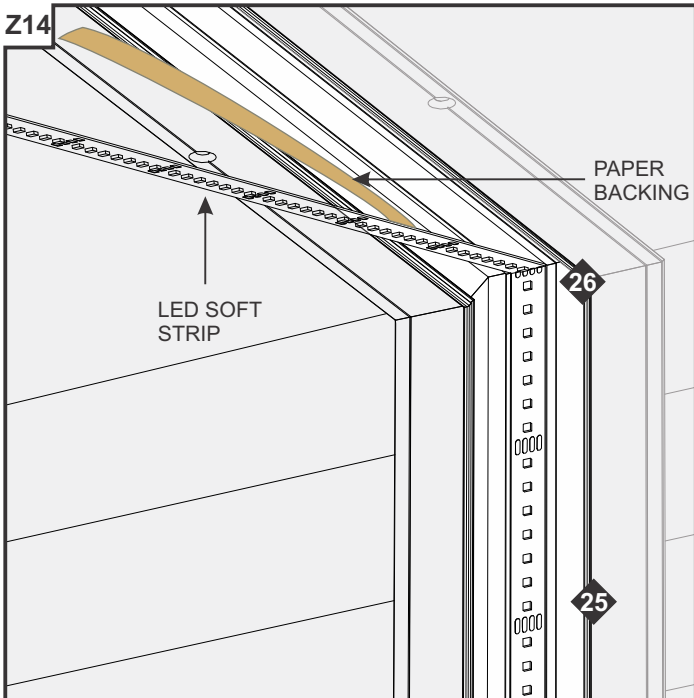

25: Continue removing the paper backing from the soft strip and installing along channel, pressing adhesive into place using **ONLY** a finger.

26: Bend the soft strip to match the installation corner. Ensure the entire length of the channel is covered with Soft Strip to avoid unlit areas.

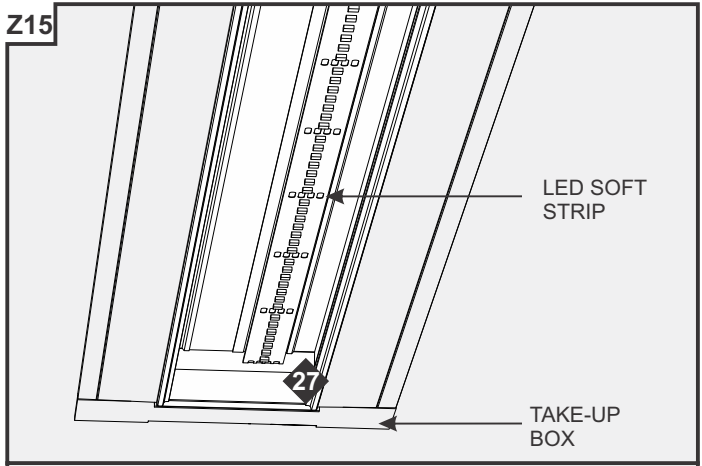

27: If required, trim the soft strip on the dashed cutting lines. Place the excess soft strip inside the take-up box.

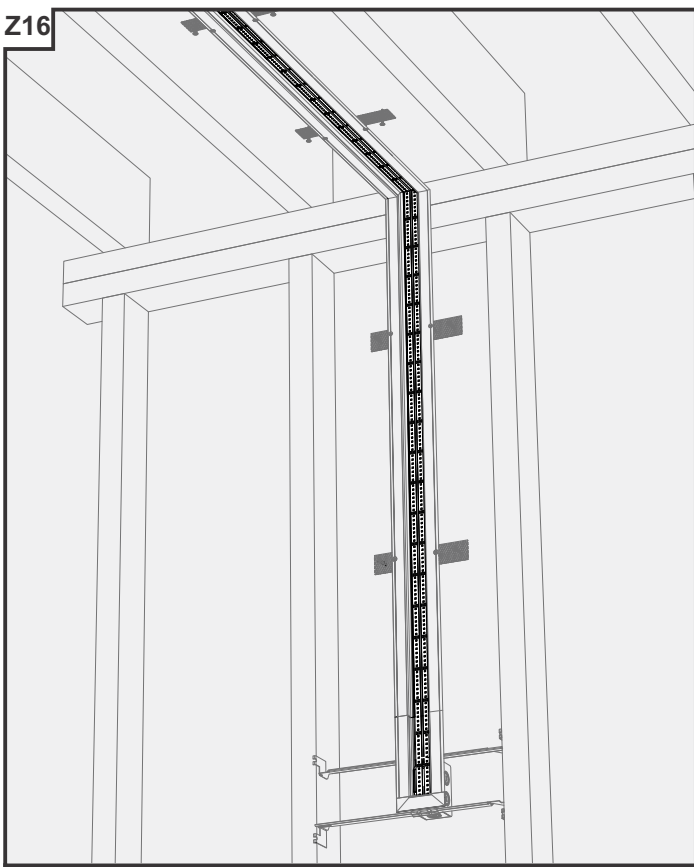

28: Repeat Steps 22 through 27 to install the second LED soft strip to the channel.

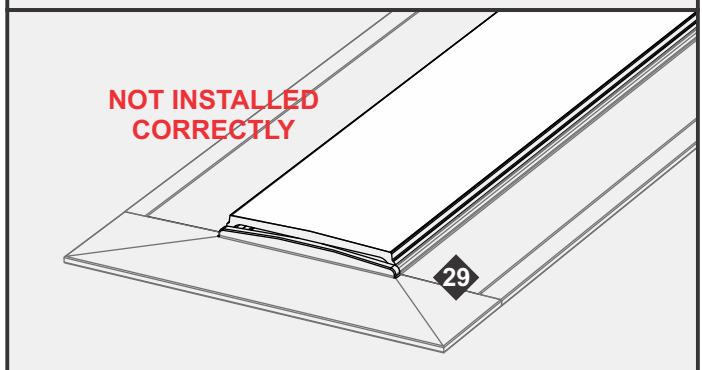
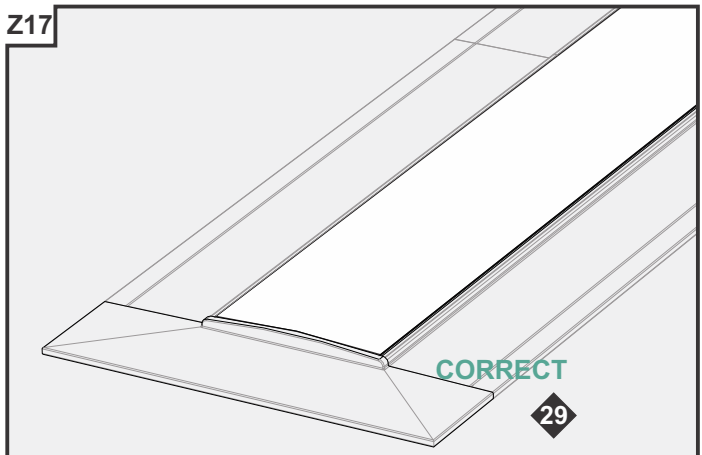

29: Snap the lens back onto the channel sections. Ensure lens is fully seated.

Section Five: Zig Zag Installation

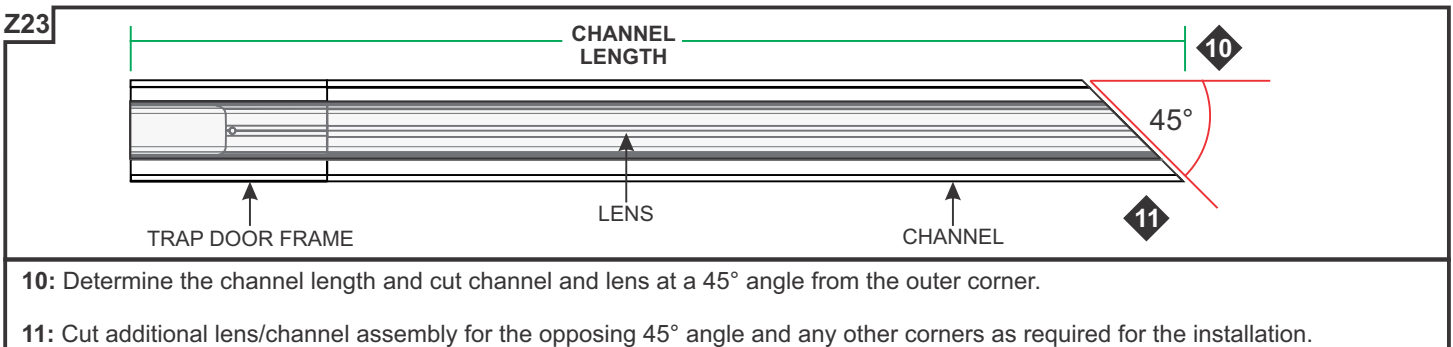
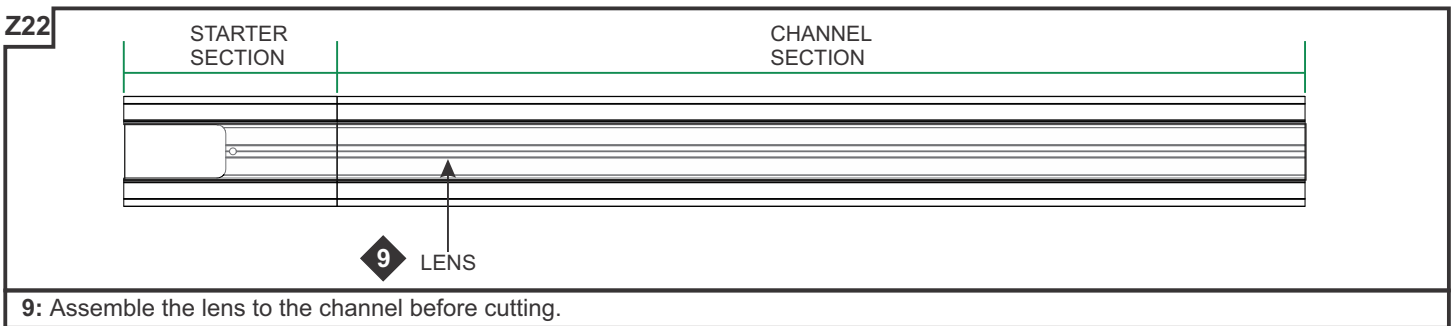
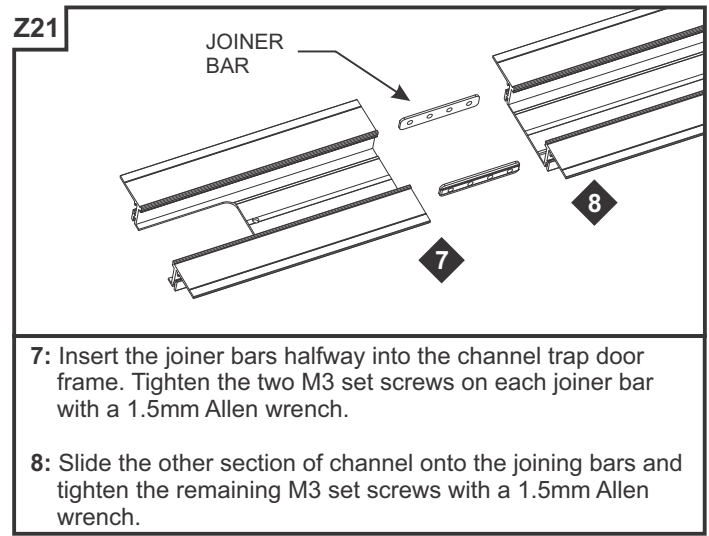
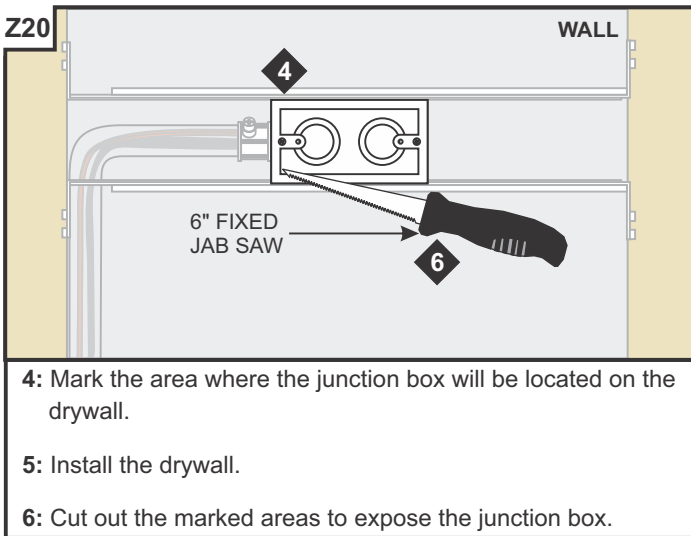
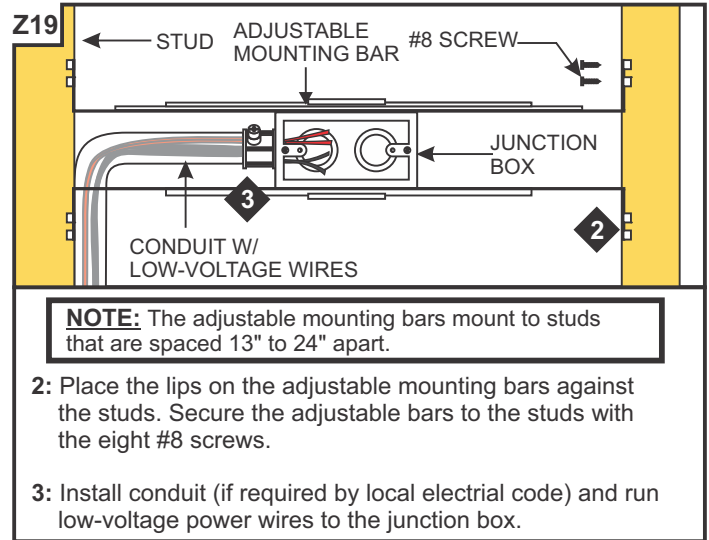
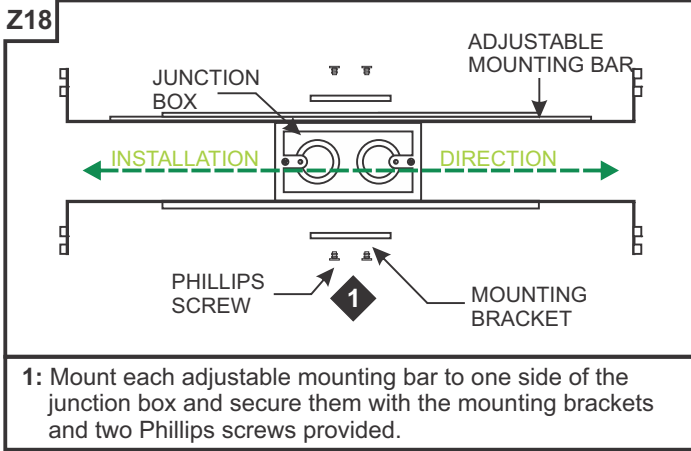

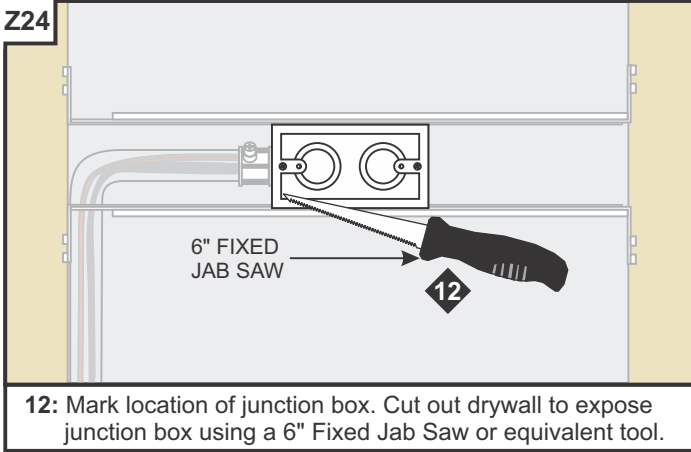

12: Mark location of junction box. Cut out drywall to expose junction box using a 6" Fixed Jab Saw or equivalent tool.

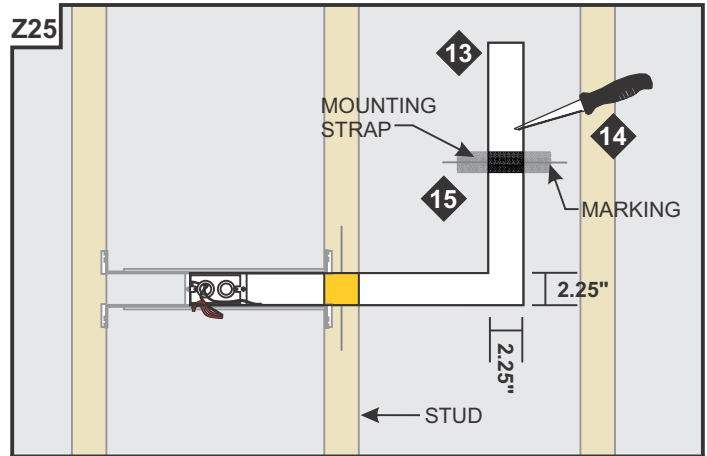

13: Mark the area where the channel will be located on the drywall using the junction box opening as a guide (**MIN** 2.25" wide).

14: Cut out the marked area(s) using a Dremel Multi-Max or a 6" Fixed Jab Saw.

15: Mark the location of the studs to the drywall for future reference.

NOTE: To install channel vertically or in a wall without standard-spaced studs, install perforated mounting straps every 32" behind drywall and secure using two drywall screws. Mark the location of any mounting straps to the drywall.

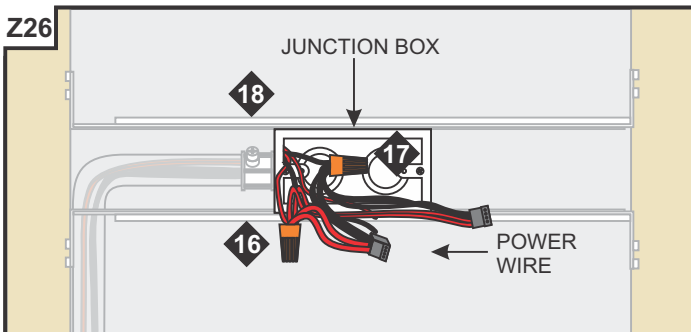

NOTE: Remote power supply wires must be present in junction box. Refer to instructions provided with power supply.

16: Connect the red power supply (24VDC+) wires to each red power wire with a wire nut inside the junction box.

17: Connect the black power supply (24VDC-) wires to each black power wire with a wire nut inside the junction box.

18: Place the wire nut connections inside junction box.

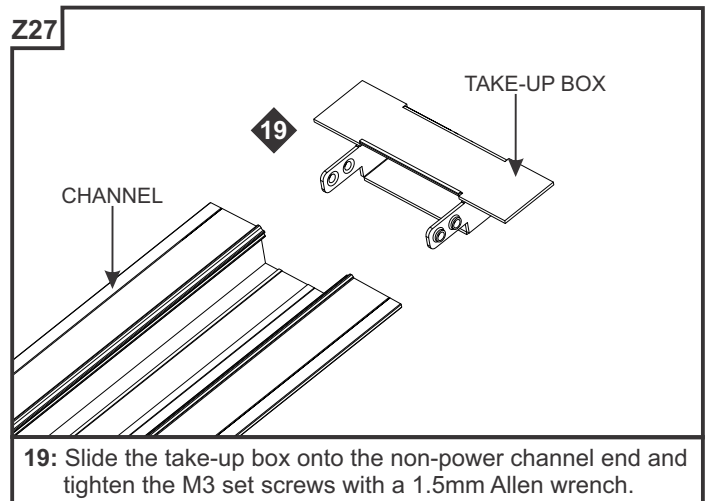

19: Slide the take-up box onto the non-power channel end and tighten the M3 set screws with a 1.5mm Allen wrench.

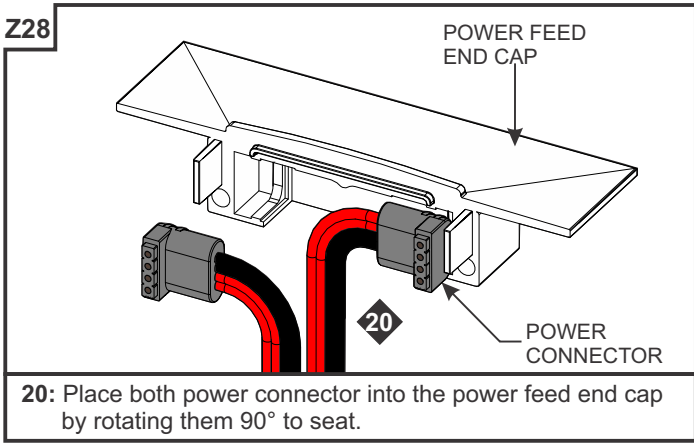

20: Place both power connector into the power feed end cap by rotating them 90° to seat.

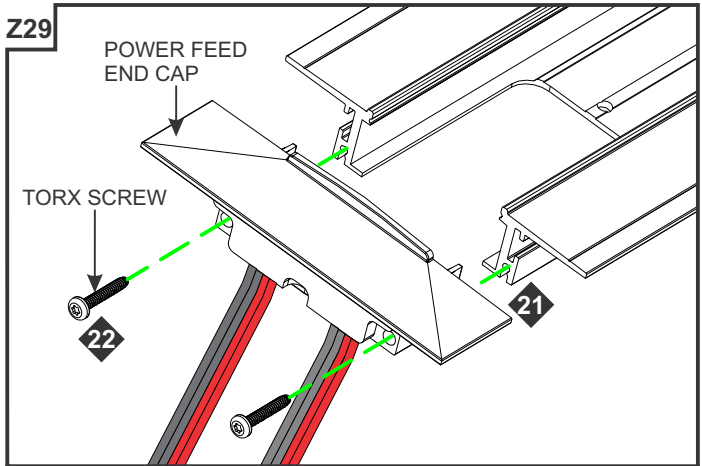

21: Insert the #4-40 Torx screws through the end cap holes and thread into the power end of the TruLine 1.6A channel.

22: Tighten the end cap to the channel using the provided T10 Torx screwdriver.

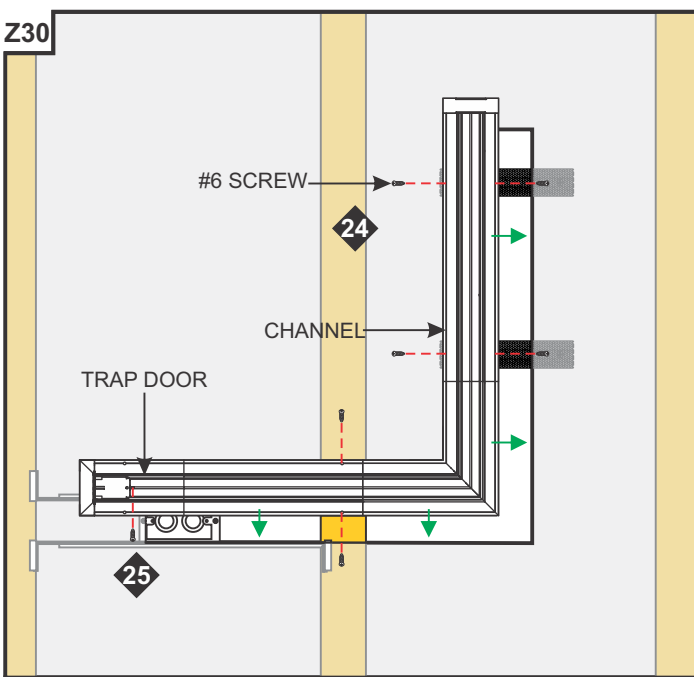

23: Using the mark locations on the drywall, carefully make a hole to channel using the provided square drill with counter sink bit.

24: Secure the channel to the studs/mounting straps through the drywall with the #6 screws using the provided square recess bit.

25: Secure the Trap Door channel section to the junction box with the supplied screw.

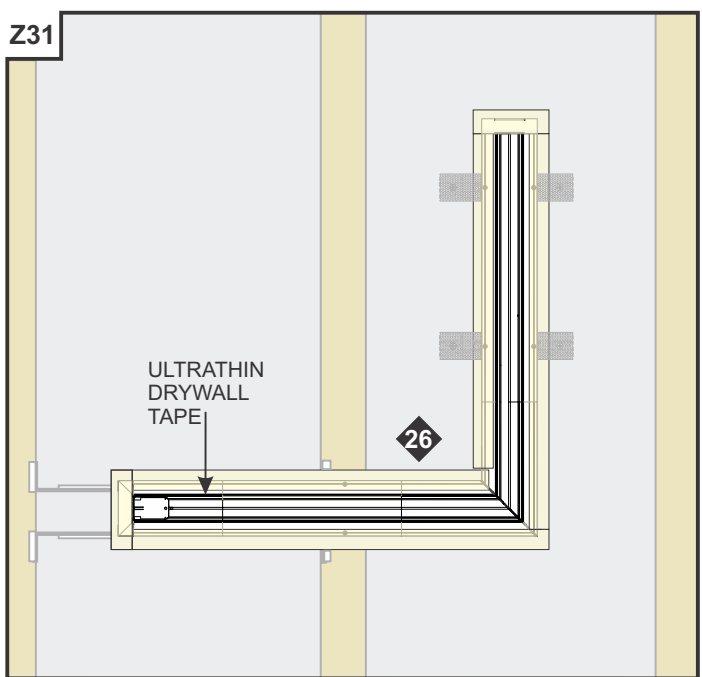

NOTE: Test the LED strip before any plaster work is done.

NOTE: Cover the channel opening with blue contractor's tape before plastering.

26: Apply ultra-thin drywall tape along edges of channel to prevent cracking of plaster after installation. **DO NOT** overlap strips of drywall tape.

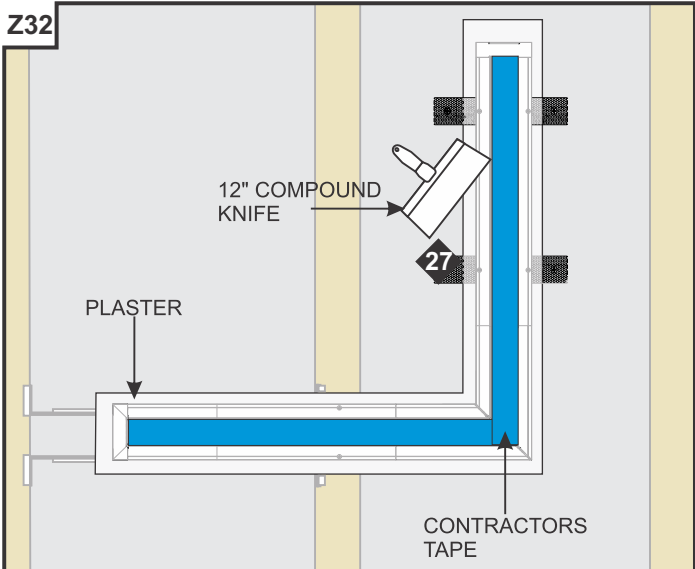

27: Use a 12" compound knife for a smooth compound spread. Sand, paint, and finish the plaster and drywall before removing the blue contractors tape.

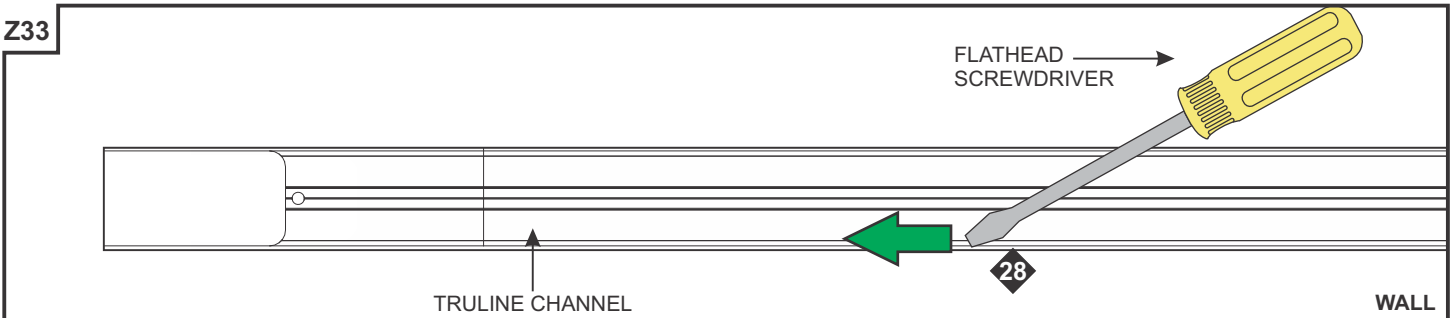

28: Carefully use a flathead screwdriver to remove excess drywall from the internal bevel/edge.

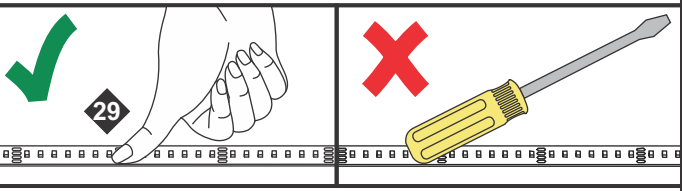
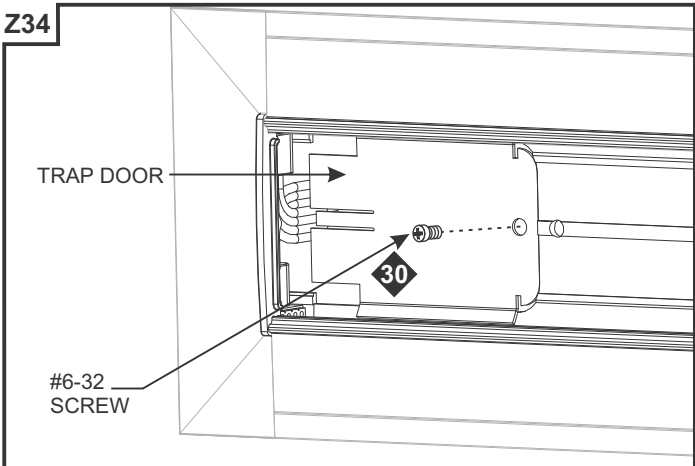

29: Remove the blue contractors tape from the inside of the channel. Clean the channel surface with alcohol to remove any dust or debris before continuing.

30: Attach the trap door to the junction box using the #6-32 screw.

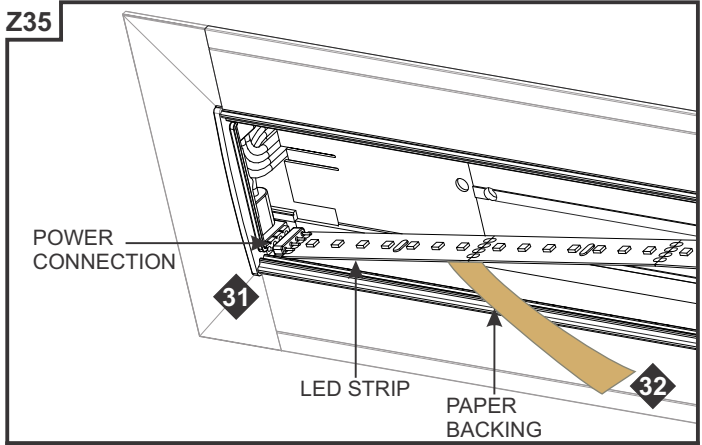

NOTE: If installation requires RGB, RGB+W, or Tunable White, refer to wiring diagrams on pages 19-21.

31: Line up the red wire side of the power connector with the "+24VDC" marking on the Soft Strip. Push the male connector of the Soft Strip into the female connector of the power cables.

32: Carefully remove the backing from the LED soft strip, making sure not to remove the tape from the soft strip. Firmly press down the adhesive portion of the soft strip onto the channel surface while removing the rest of the backing, making sure there are no air bubbles that can cause surface irregularities.

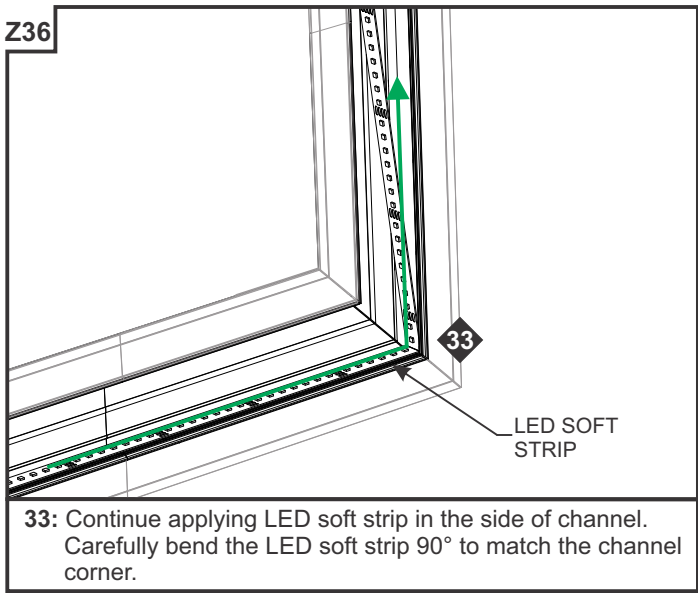

33: Continue applying LED soft strip in the side of channel. Carefully bend the LED soft strip 90° to match the channel corner.

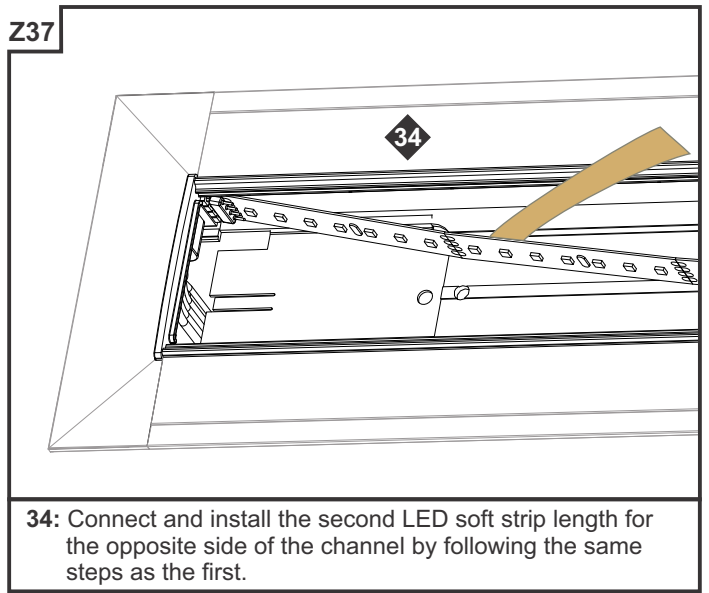

34: Connect and install the second LED soft strip length for the opposite side of the channel by following the same steps as the first.

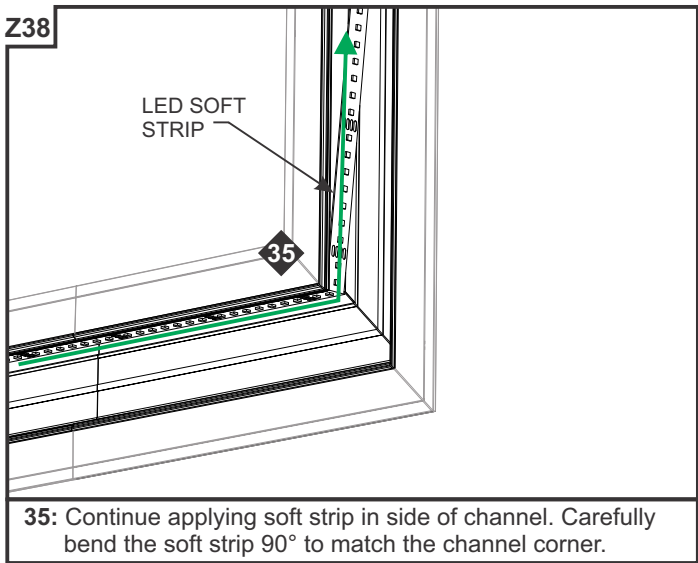

35: Continue applying soft strip in side of channel. Carefully bend the soft strip 90° to match the channel corner.

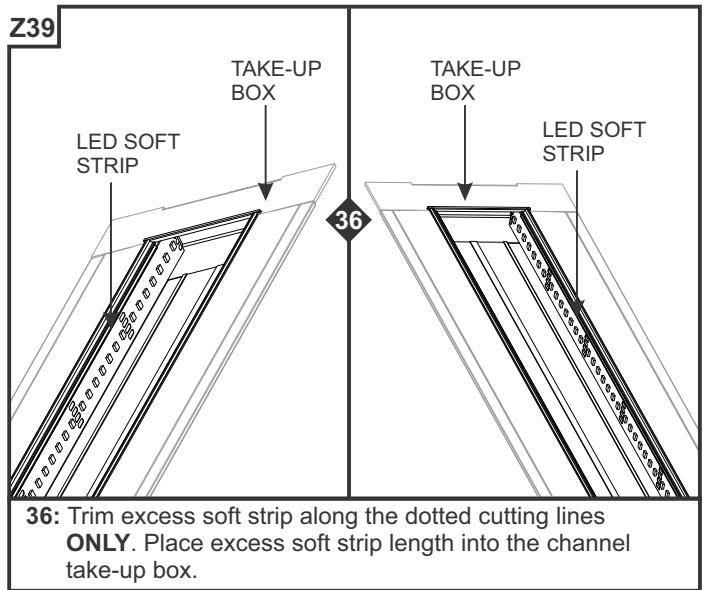

36: Trim excess soft strip along the dotted cutting lines **ONLY**. Place excess soft strip length into the channel take-up box.

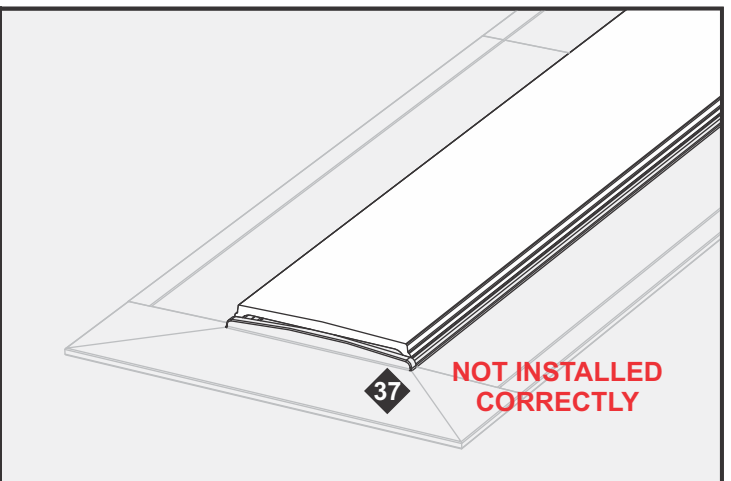
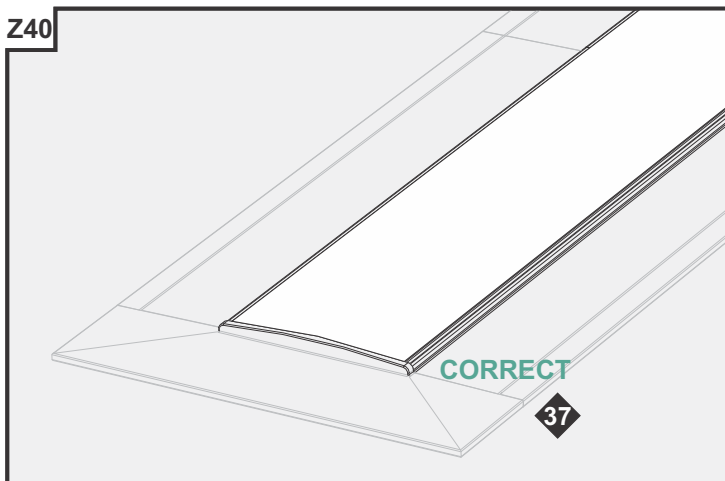

37: Snap the lens back onto the channel. Ensure lens is fully seated.

Section Six: Wiring Diagrams

General 24VDC Configuration

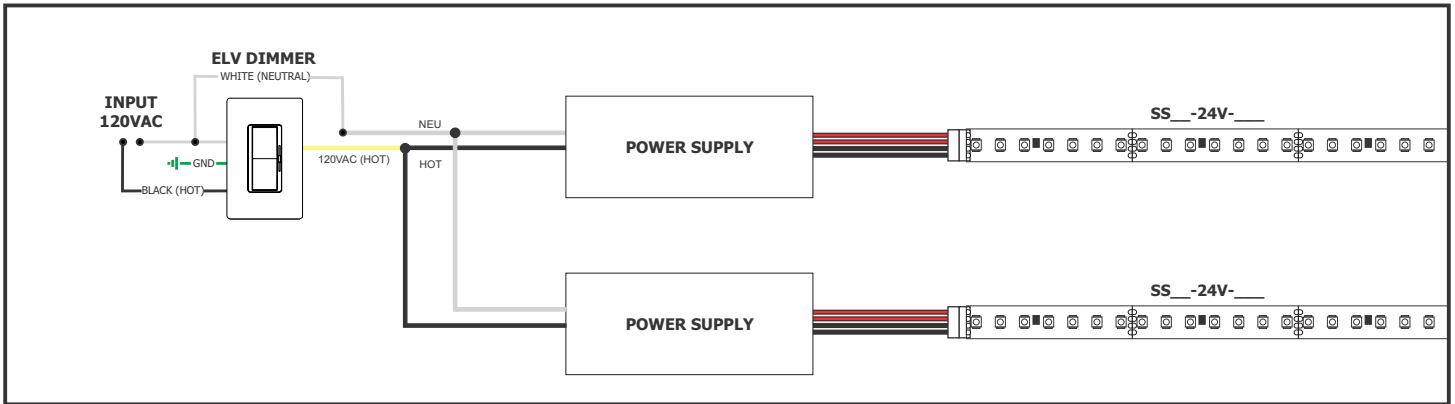

Standard RGB Configuration

Using LED Power Supply with RGB Soft Strip & CDP or CTP Control

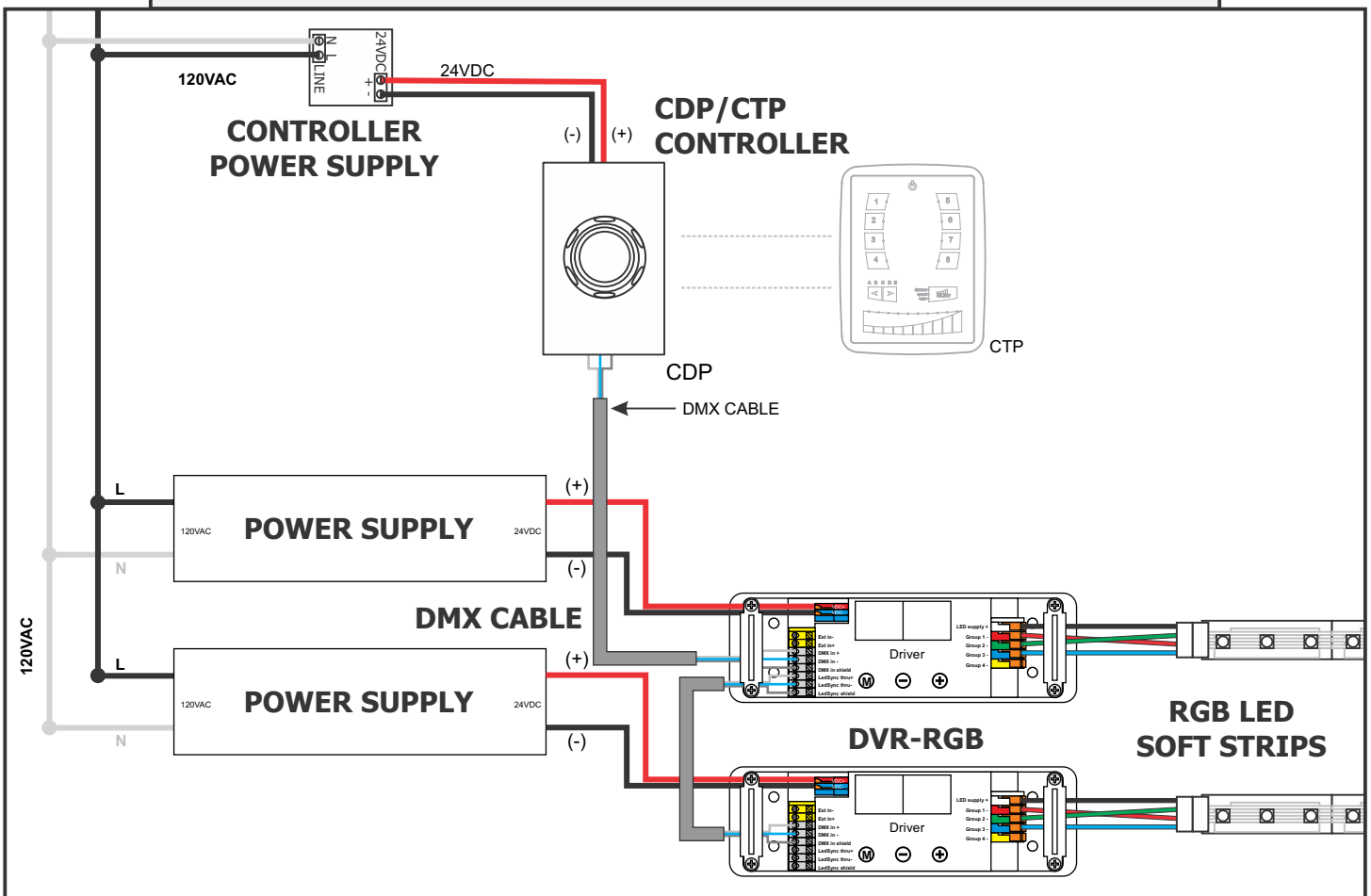

RGB+W Configuration

Using LED Power Supply with RGB+W Soft Strip & CDP or CTP Control

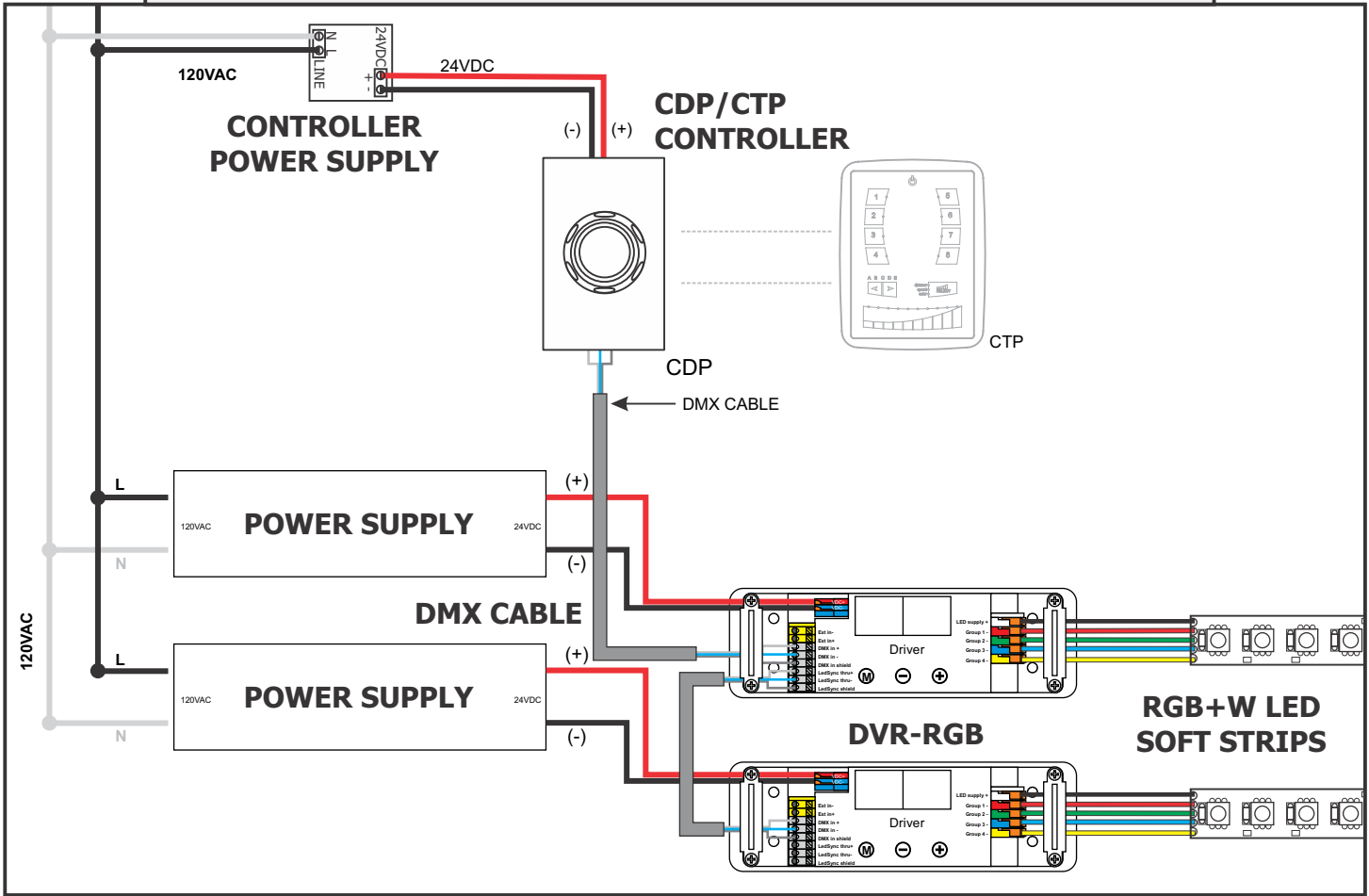

Tunable White Configuration

Dual Power Supplies Controlled Via Individual ELV Dimmers

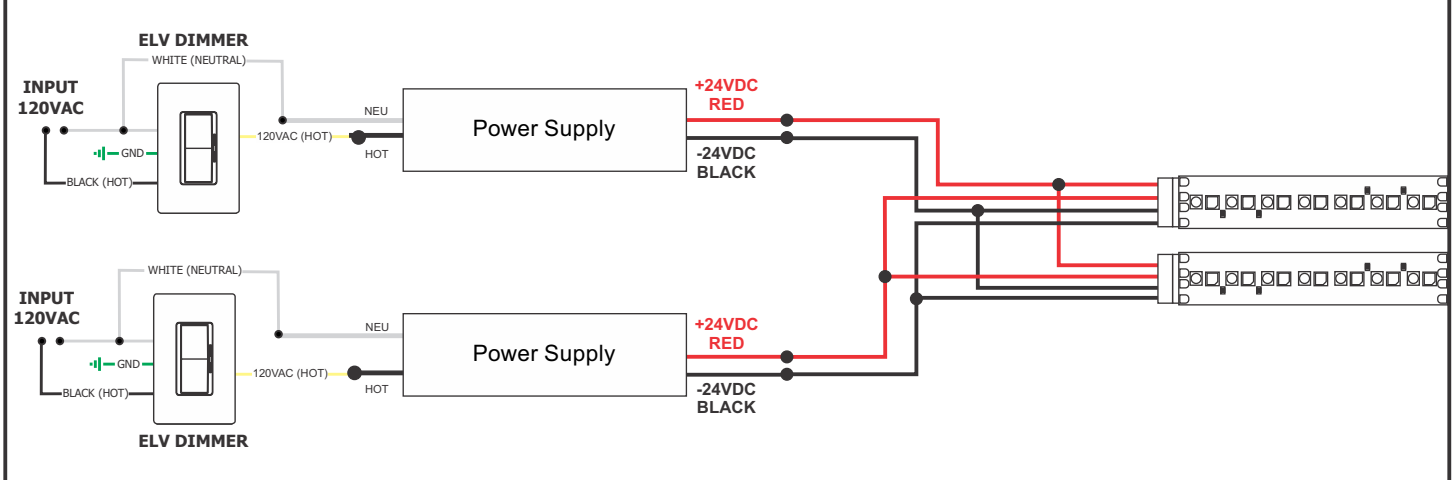

Tunable White Configuration

RGB Power Supply with DMX Controller

If using a CDP Color Dial, configure your CDP to Warm White mode using DIP switches and follow CDP operating instructions:

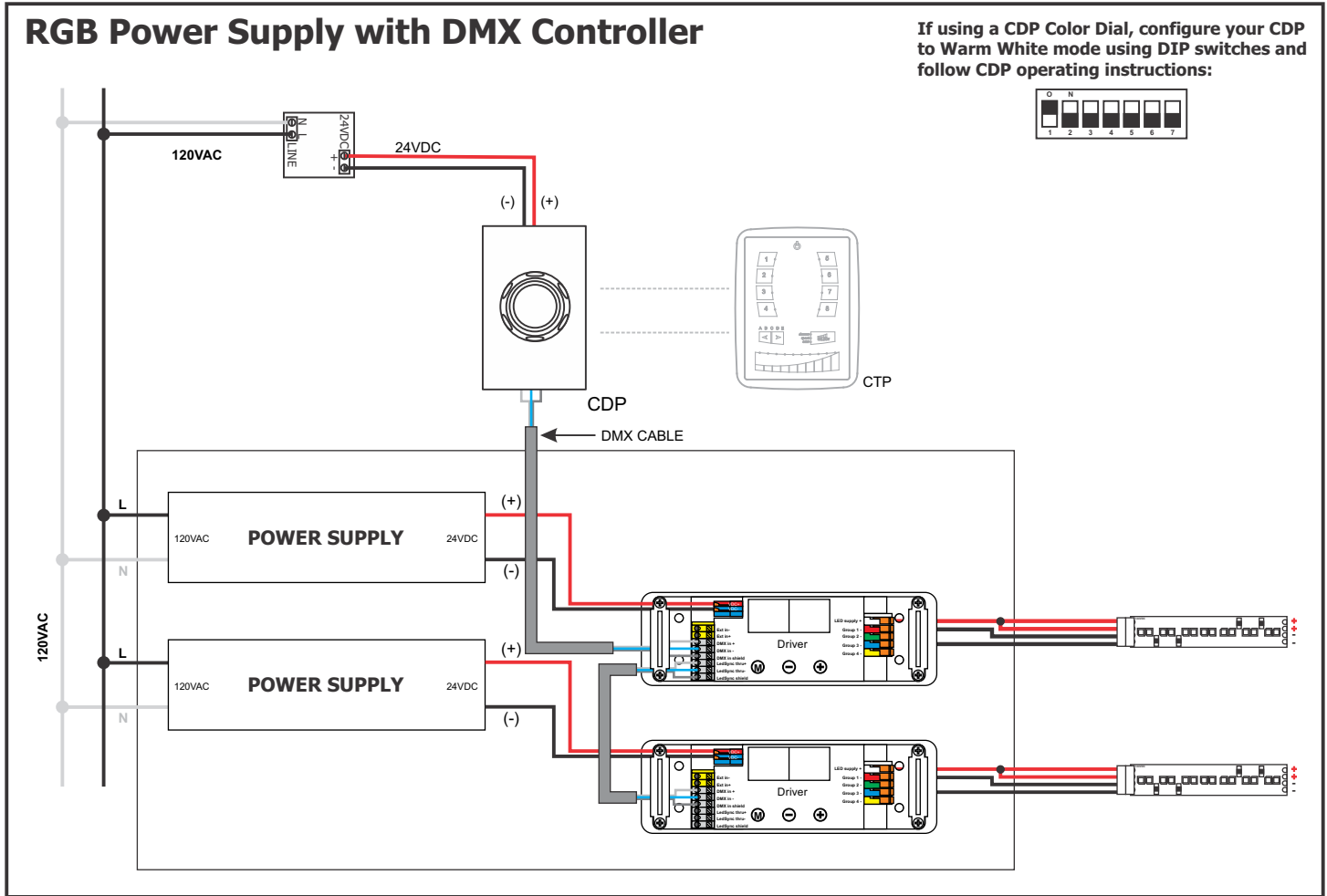

IMPORTANT INFORMATION REGARDING INSTALLATION AND REWORK OF SOFT STRIP LED

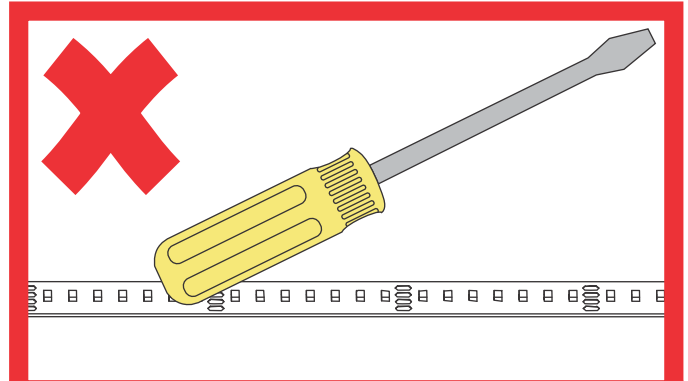
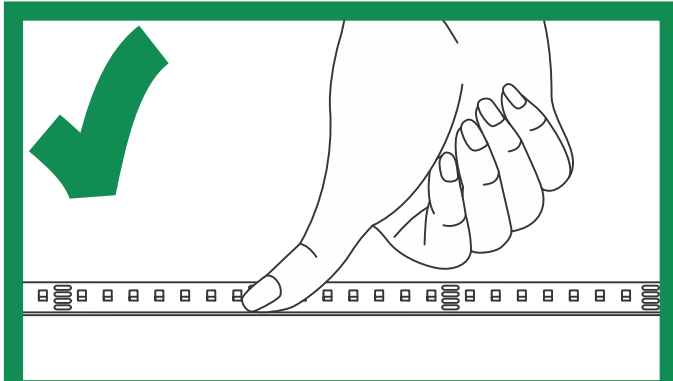
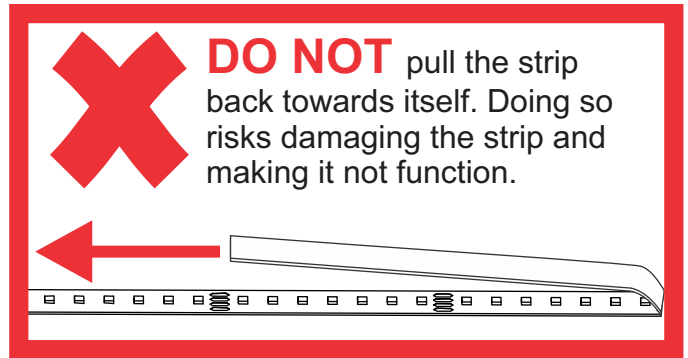
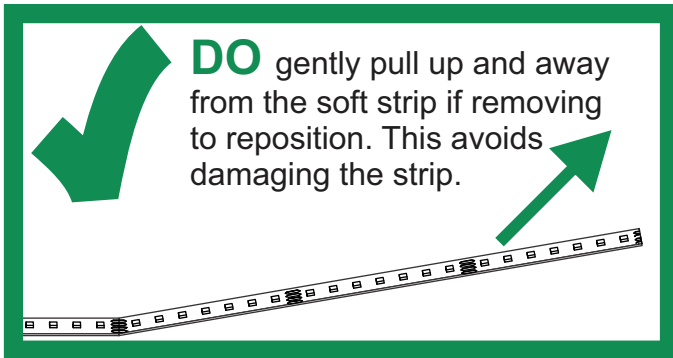

DO only ever use fingers to gently install soft strip to a surface **AFTER** cleaning the surface with alcohol.

DO NOT use any tool to install soft strip to a surface. This will damage the soft strip component.

Relocating Soft Strip (Optional)

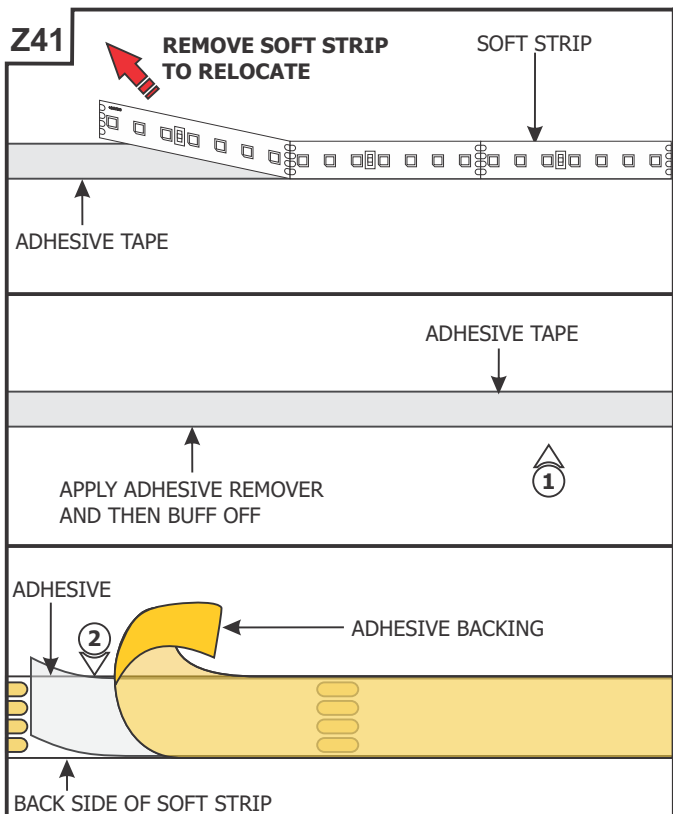

NOTE: If relocating the installed soft strip, make sure that the adhesive tape on back of the soft strip covers the entire strip. The adhesive tape isolates the strip from the installation surface. Damaged or inconsistent adhesive tape may cause the contacts on the back of the strip to come in contact with the conductive heat sink which will cause the strip to short and burn. Call Edge Lighting to get replacement adhesive tape and/or optional aluminum heat sink tape (SS-HR-F).

- 1:** To remove tape residue from back of the strip, apply WD-40, Goo Gone, or a mixture of warm water and lemon oil to the corner of a clean, dry towel. Gently buff the area containing the adhesive residue until it is completely removed.
- 2:** Gently remove a few inches of the from one side of the tape backing. Attach the adhesive tape to the back of the soft strip and apply moderate pressure to affix the tape. Continue this step a few inches at the time until the entire adhesive tape is attached to back of the soft strip.
- 3:** Refer to pages 7, 13, or 17 to reinstall the LED soft strip.