



© 2016 Pure Lighting. All Rights Reserved.

Installation Instructions For Aurora LED Accent Housing 3 Round & Square Trimless AL2-ARE3 & AL2-ASE3

1718 W. Fullerton Ave
Chicago, IL 60614
Tel: 773-770-1195
Fax: 773-935-5613
www.purelighting.com
info@purelighting.com

General Information

Fixture must be installed by a qualified electrician (check with local and national codes for proper installation). To prevent electrical shock, disconnect electrical supply before installation or servicing. Compatible only with traditional, level 5 surface finishing, not self-leveling, PVA primer systems. **Not for use in wood or tile ceilings.**

WORKFLOW CHART



ELECTRICAL CONTRACTOR

1. Locate and mount housing
2. Screw and lock-in housing
3. Connect wires in housing



DRYWALL CONTRACTOR

1. Install and cut drywall around housing.



ELECTRICAL CONTRACTOR

1. Adjust plaster flange frame and tighten wing nuts.
2. Connect the LED MR16 wiring to the plaster plate.
3. Screw plaster plate into housing.
4. Test LED MR16.



DRYWALL CONTRACTOR

1. Plaster, sand & paint.
2. Clean aperture with clean damp towel.



ELECTRICAL CONTRACTOR

1. Clean aperture with clean damp towel, where the drywall contractor missed.
2. Adjust pan rotation ring and aim lamp. You're done!

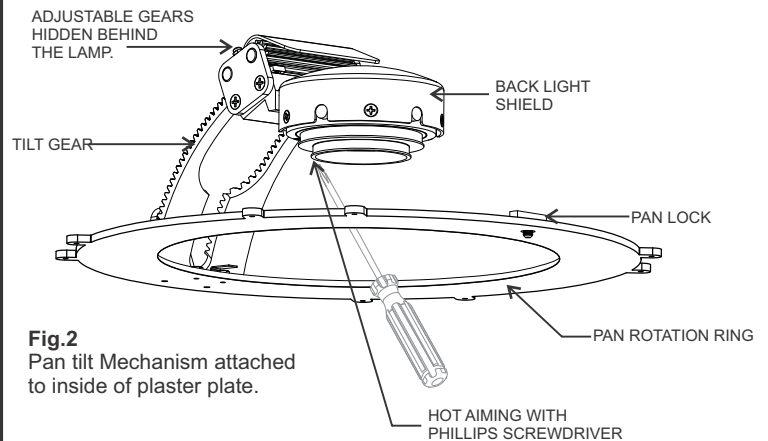
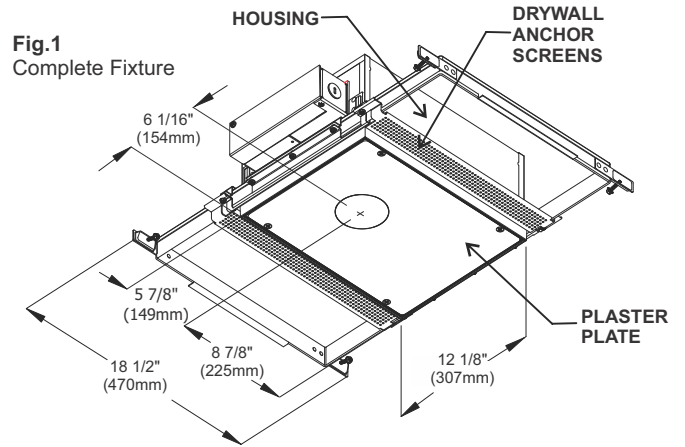

Fig.2
Pan tilt Mechanism attached to inside of plaster plate.

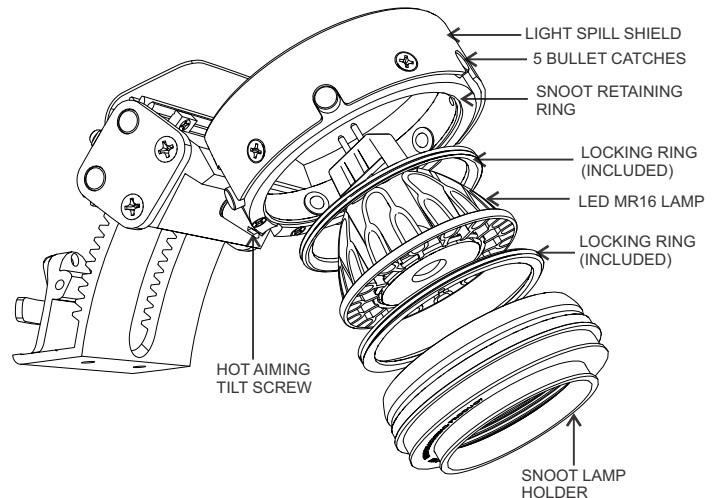

Fig.3
Snoot Assembly



Important

Scan with your mobile device to watch the installation video or visit:

www.purelighting.com/aurora-install

Importante

Escanear con el dispositivo móvil para ver el video de instalación o visite:

www.purelighting.com/aurora-install



ELECTRICAL CONTRACTOR

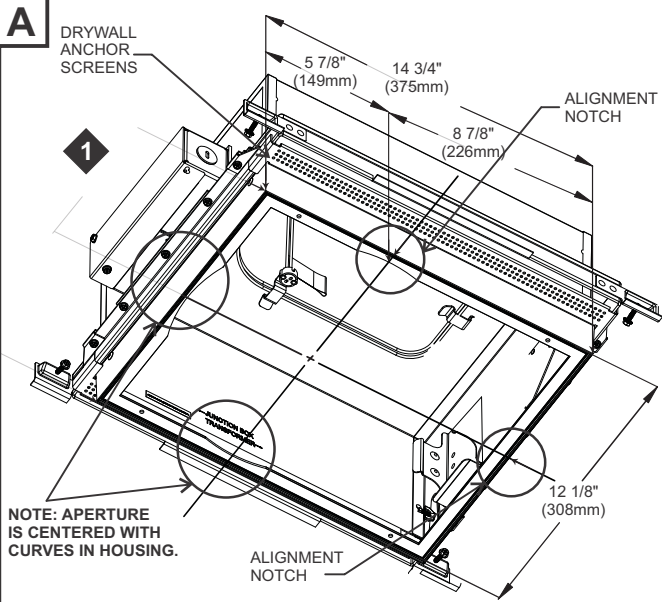

1: Use these dimensions when locating the center point of the aperture during the installation process. Align the fixture using a laser or a chalk line.

NOTE: Drywall anchor screens may be removed, if the joist are less than 14 1/2" apart. Refer to page 8 to shorten the hanger bars,

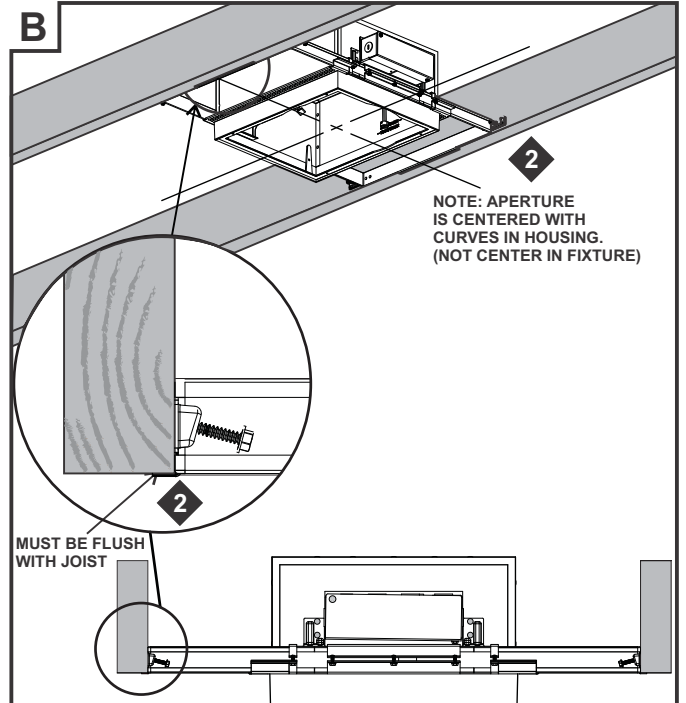

2: Hanger bars must align and remain flush with joist.

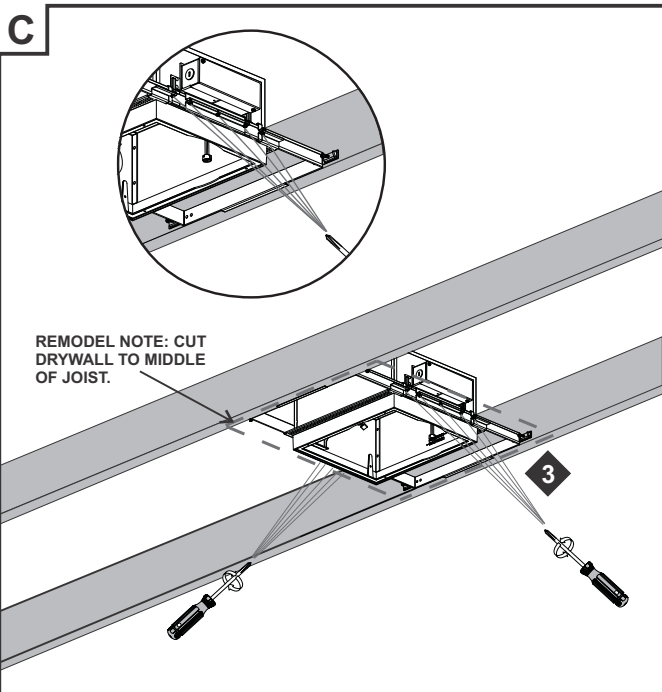

3: After fixture is positioned, tighten all (10) screws on hanger bars.

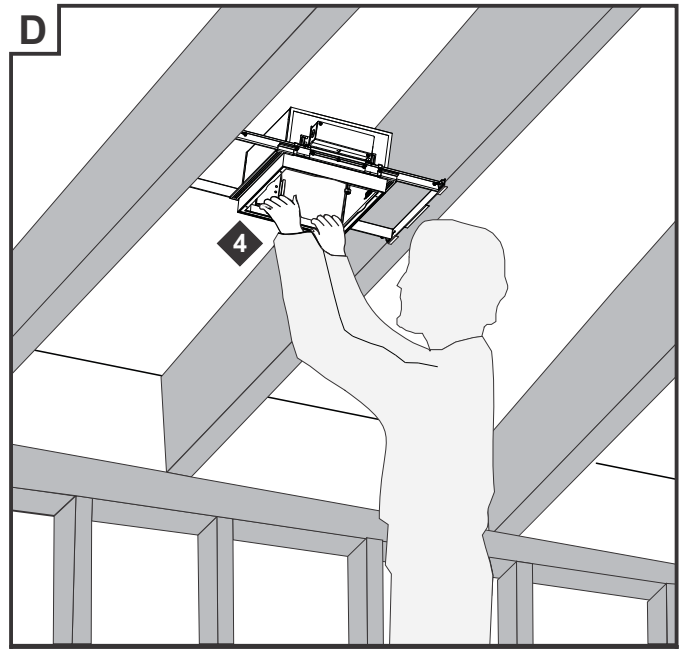

4: After installation, pull on fixture to ensure there is no movement.

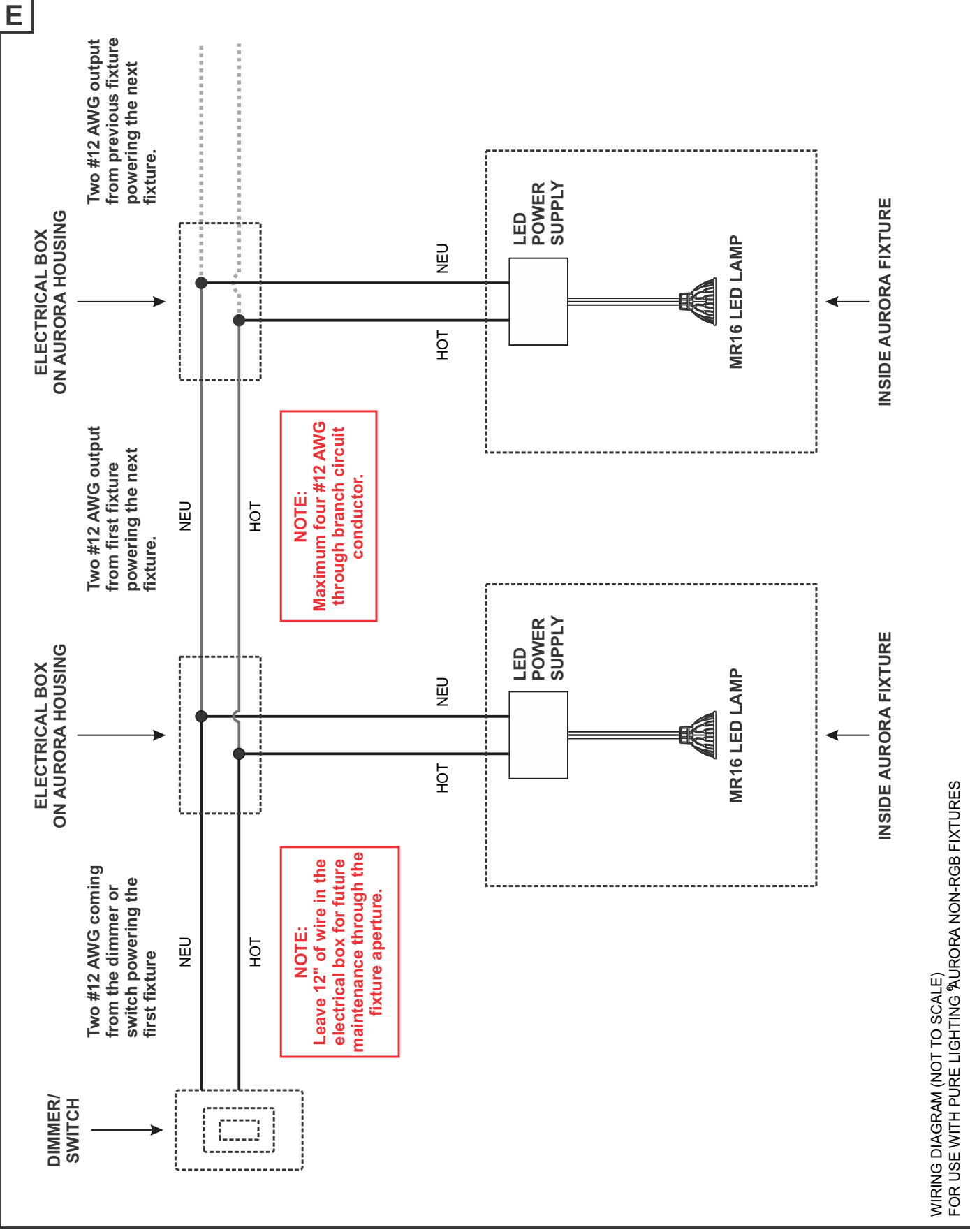

WIRING DIAGRAM (NOT TO SCALE)
FOR USE WITH PURE LIGHTING AURORA NON-RGB FIXTURES

DRYWALL CONTRACTOR

F Contratista hojas de pared tiene que instalar la hoja de pared y corte un agujero 14 3/4" (375mm) X 12 1/8" (308mm) con una corte rotatorio alrededor el enseres fijo o lo corte un agujero antes que instalar.

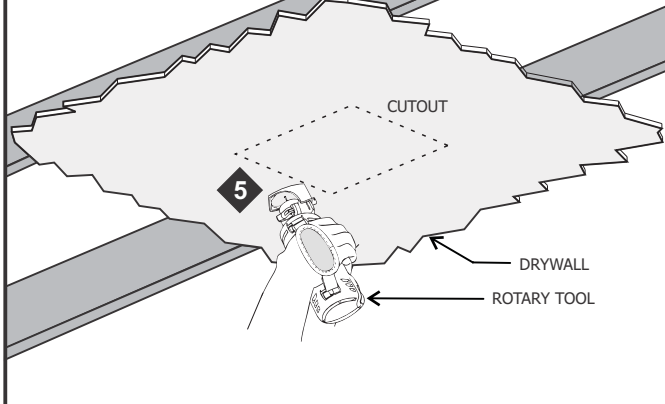

5: Drywall contractor must install drywall and cut 14 3/4" (375mm) X 12 1/8" (308mm) hole with rotary cutting tool around fixture or pre-cut hole in drywall prior to installation.

ELECTRICAL CONTRACTOR

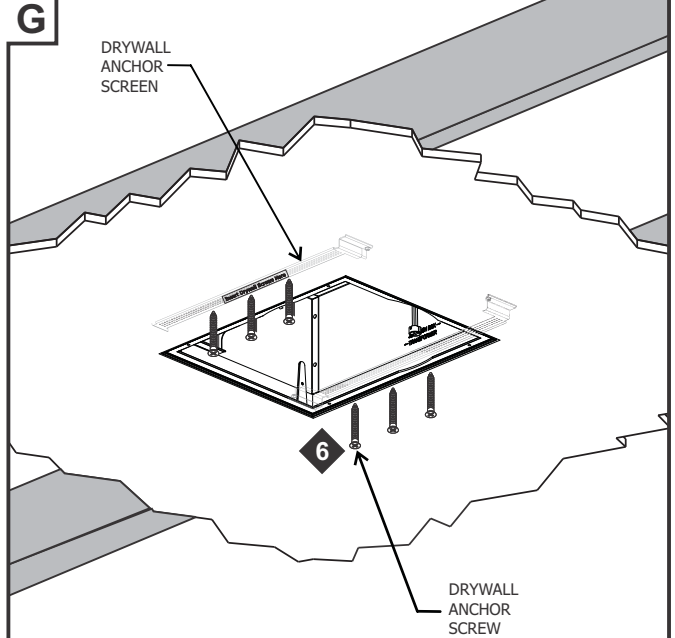

6: Electrician must anchor drywall anchor screens. Insert screws through drywall into anchor screen on fixture.

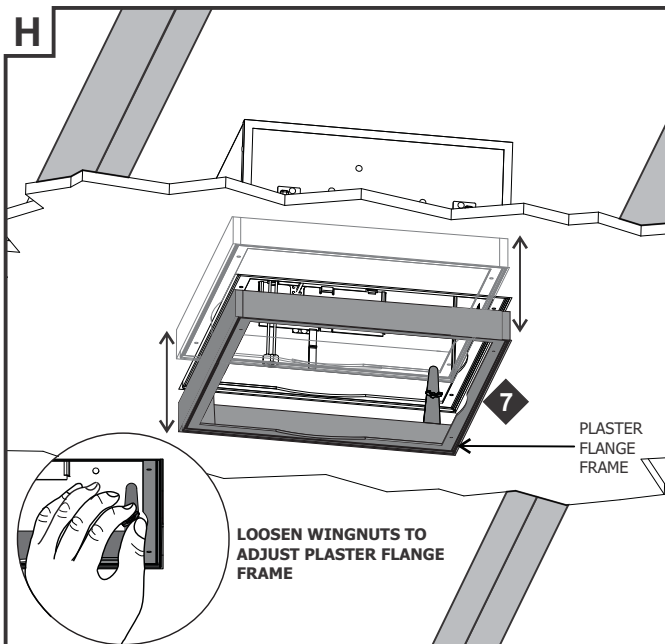

7: Loosen (4) wing nuts and adjust plaster flange frame to be flush with drywall. All 4 corners **MUST** be exactly even with drywall. Plaster flange frame adjusts to accommodate 1/2" (13mm) to 1 1/4" (32mm) ceiling thickness.

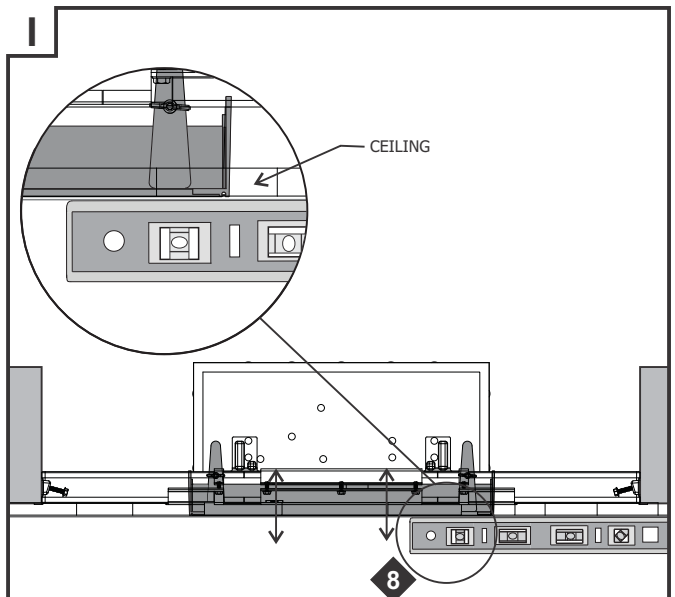

8: Use a straight edge or level and move plaster flange frame up or down to be exactly even with drywall ceiling.



ELECTRICAL CONTRACTOR

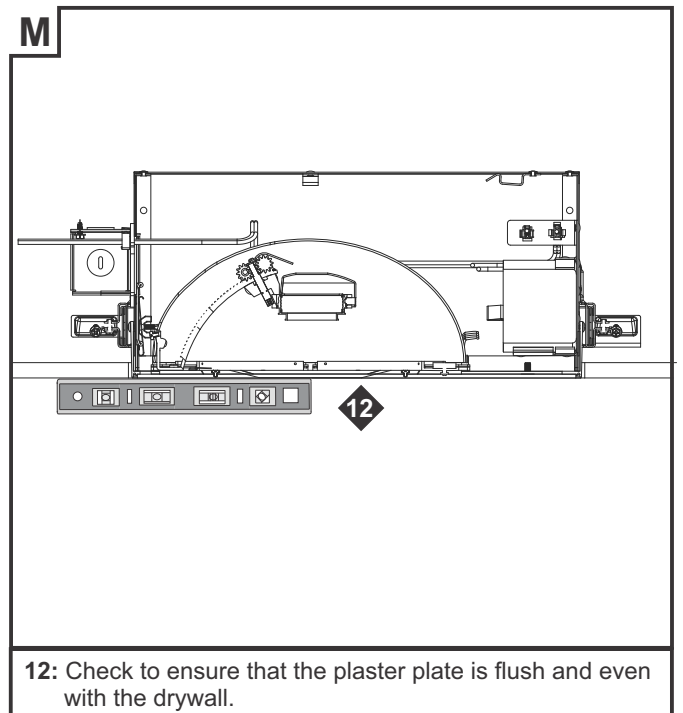
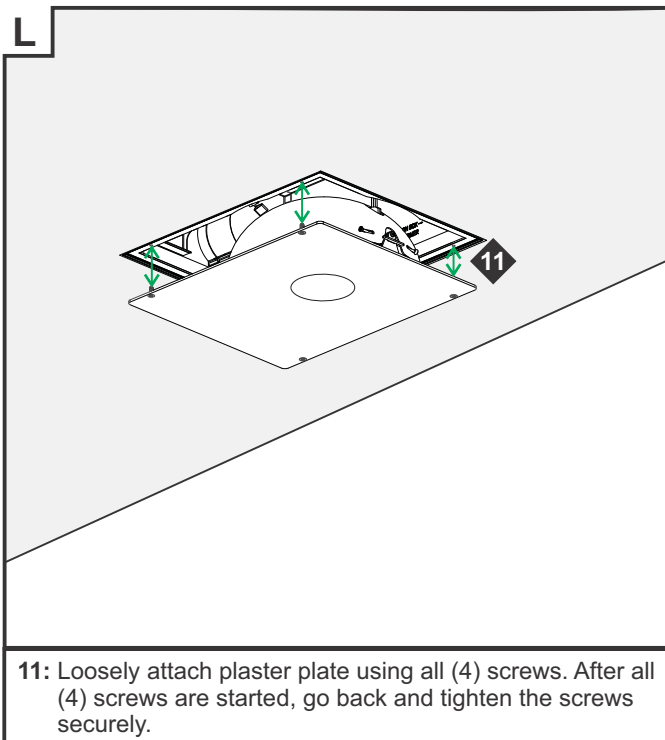
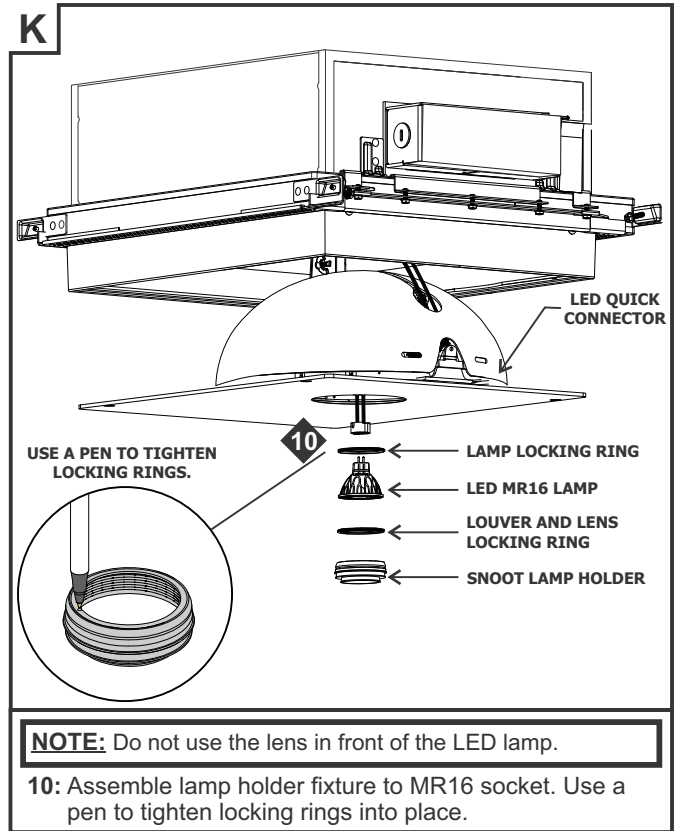
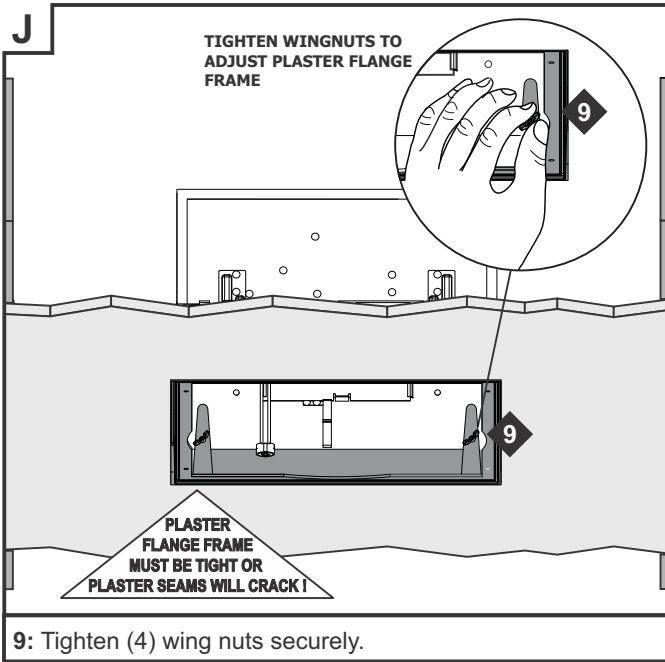



N

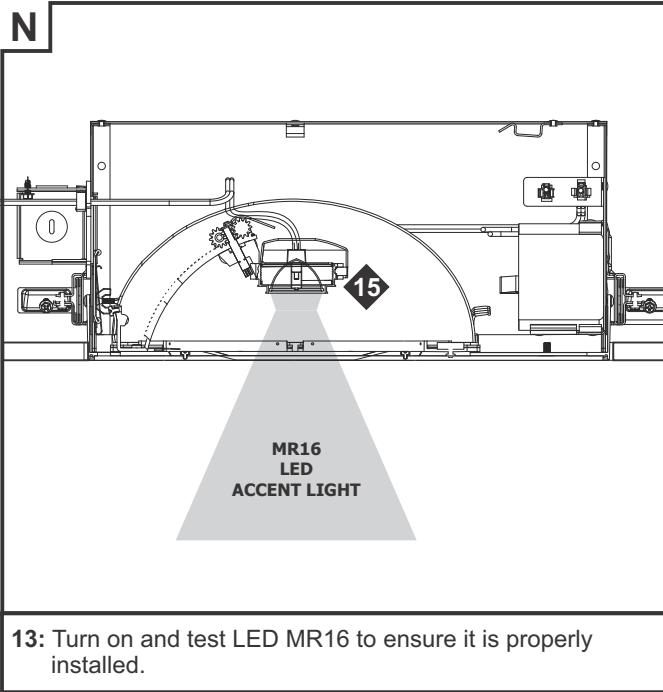

O

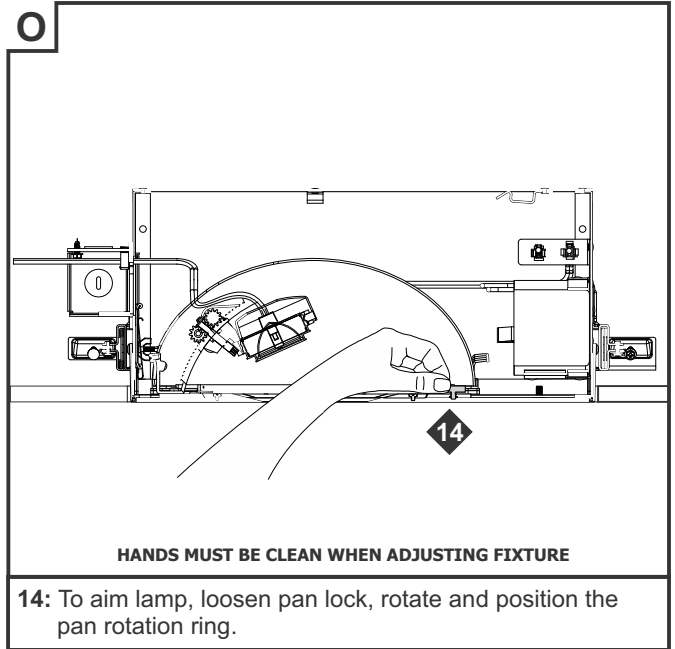

P

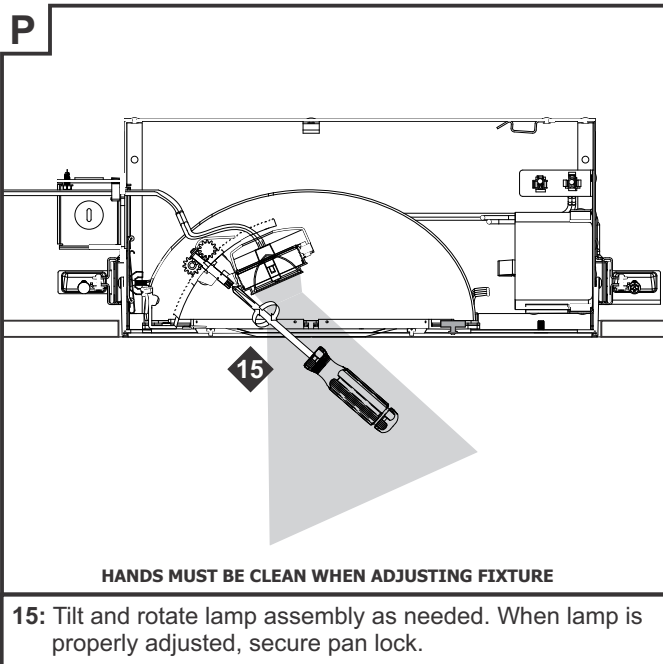

Q

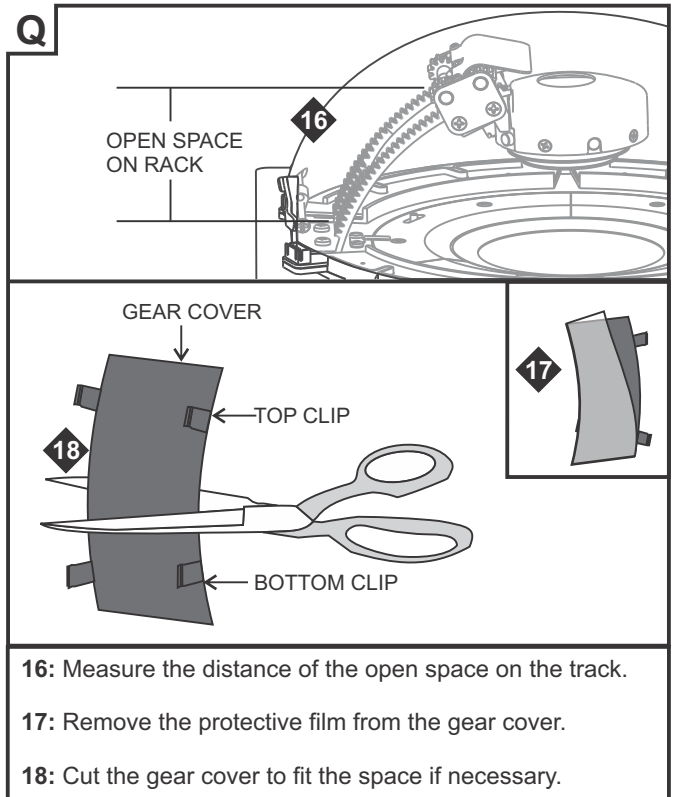



ELECTRICAL CONTRACTOR

R

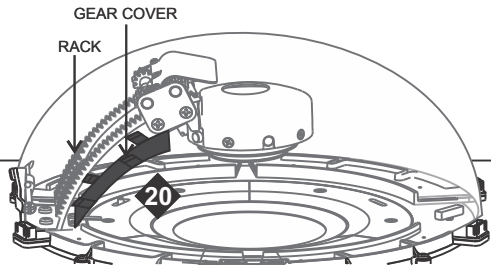
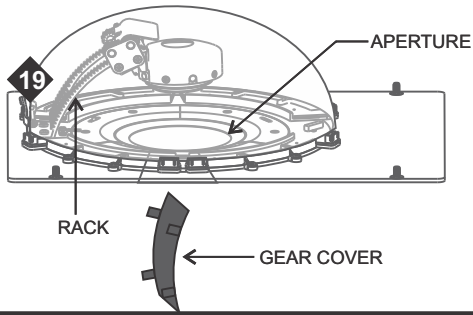

19: Insert the gear cover (make sure the gear cover clips are facing the lamp assembly rack) from the bottom of the aperture.

20: Secure by snapping in the two bottom clips of the gear cover first to the bottom edge, then snap in the top two clips to the top edge.



DRYWALL CONTRACTOR

Compatible only with traditional, level 5 surface finishing, not self-leveling, PVA primer systems.

S

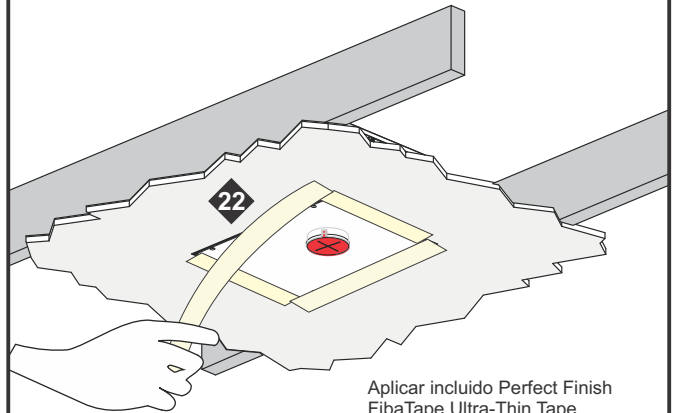

Aplicar incluido Perfect Finish FibaTape Ultra-Thin Tape alrededor de los cuatro lados

22: Apply included Perfect Finish FibaTape Ultra-Thin Drywall Tape around all four sides of the plaster plate. **DO NOT OVERLAP.**

T

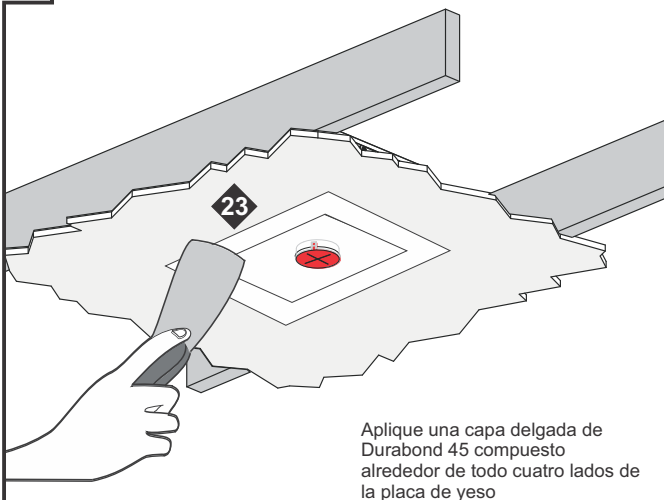

Aplique una capa delgada de Durabond 45 compuesto alrededor de todo cuatro lados de la placa de yeso

23: Apply a thin layer of Durabond 45 compound around all four sides of the plaster plate.

U

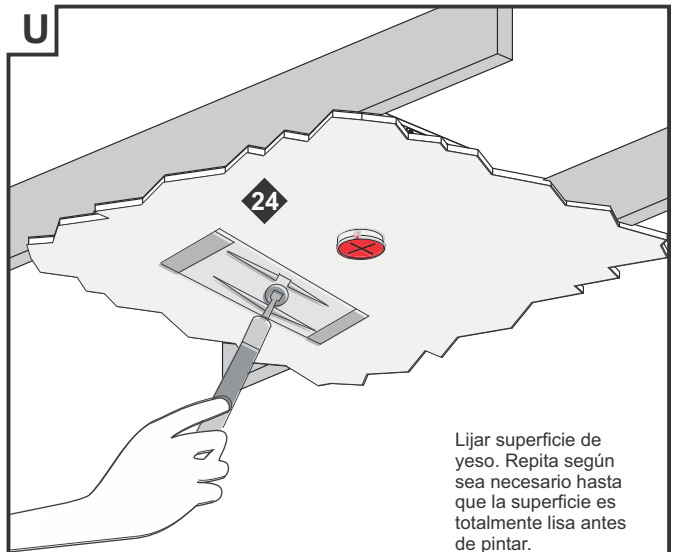

Lijar superficie de yeso. Repita según sea necesario hasta que la superficie es totalmente lisa antes de pintar.

24: Sand plastered surface. Repeat as needed until surface is completely smooth before painting.



ELECTRICAL CONTRACTOR

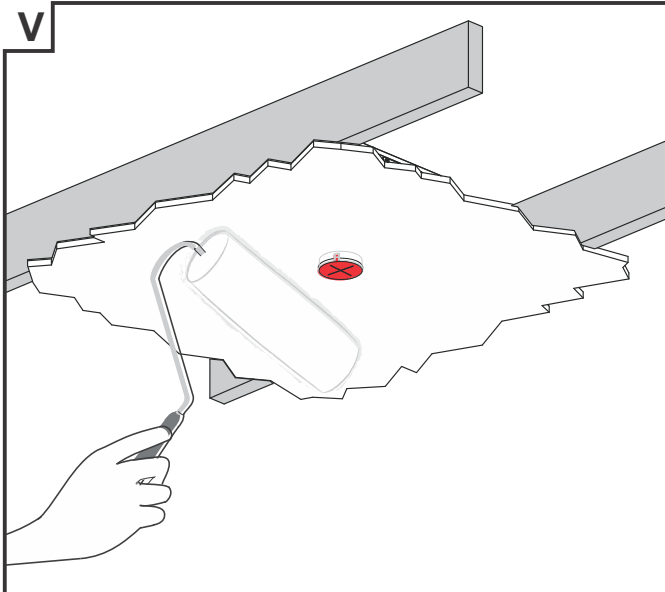

25: Paint and finish plaster plate and wall. Remove paint shield from plaster plate 20-60 minutes after painting.

26: Clean all excess paint from the aperture.

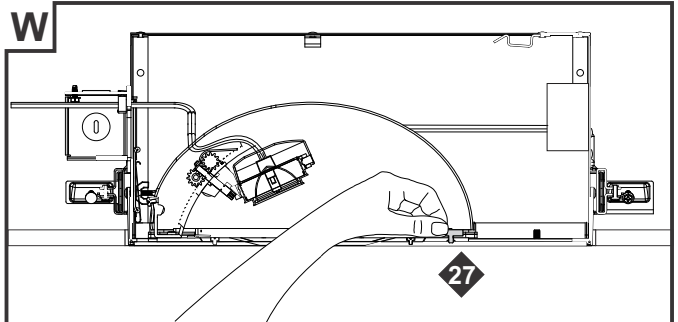

HANDS MUST BE CLEAN WHEN ADJUSTING FIXTURE

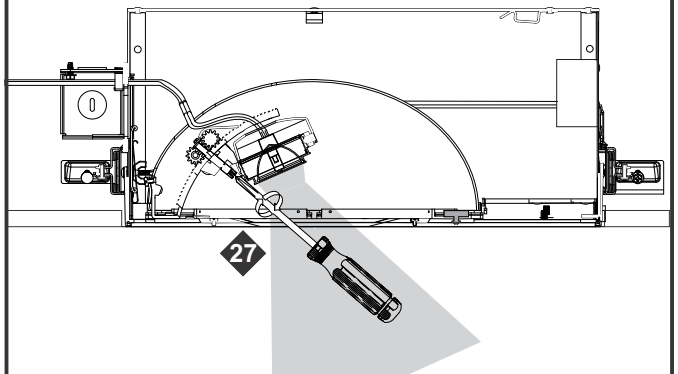

27: Wash hands and clean all drywall residue from inside aperture, with a clean damp towel. Electrician or lighting designer - ensure pan rotation ring is adjusted, locked in place, and the lamp is aimed properly.

SHORTENING THE HANGER BAR (ONLY FOR JOISTS SPACED LESS THAN 14.5")

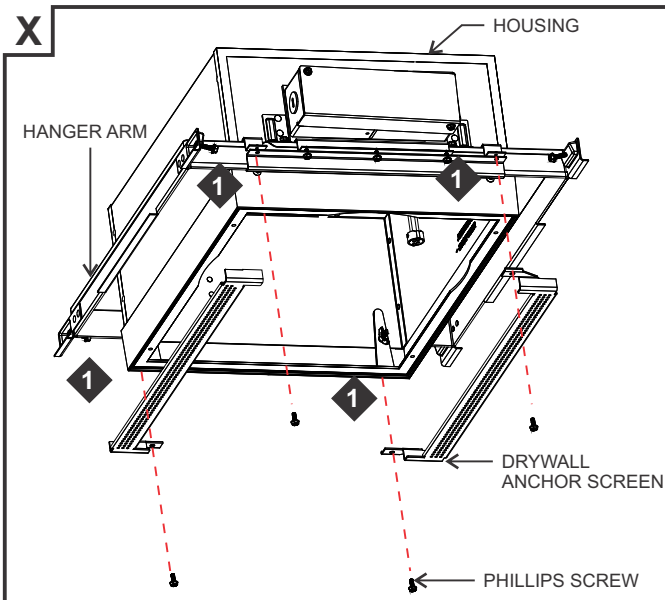

1: Remove the four Phillip screws on the housing to remove the two anchor screens, and put the screws back on.

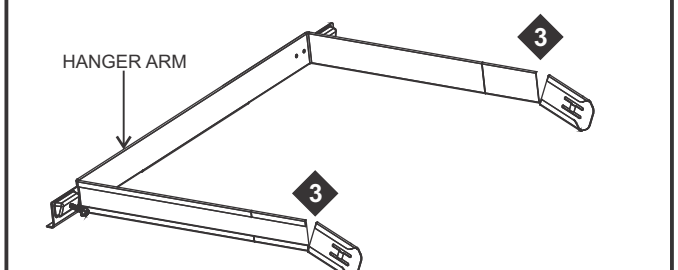
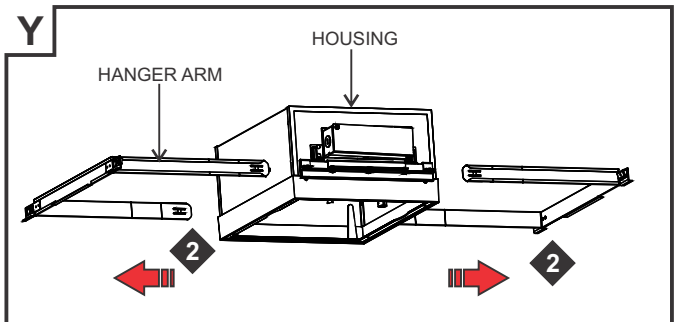

2: Pull the hanger arms completely out of the housing.

3: Break the ends completely off hanger arms.

Z

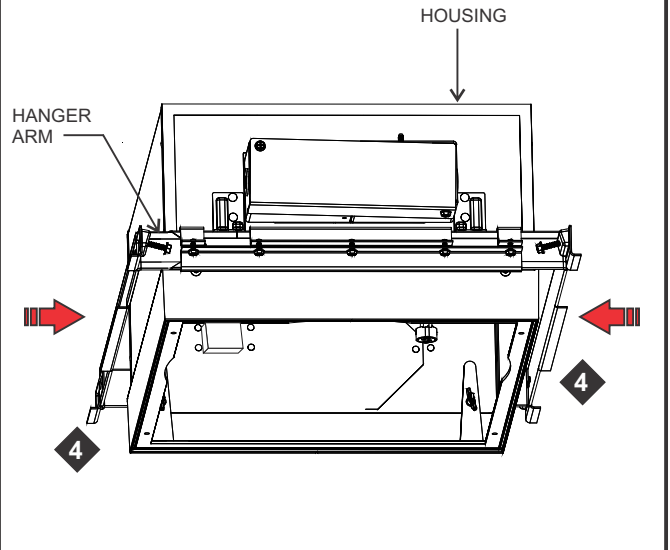

4: Insert the hanger arms back into the housing, and continue to step A on page 2 to complete installation.