

General Information

Fixture must be installed by a qualified electrician (check with local and national codes for proper installation). To prevent electrical shock, disconnect electrical supply before installation or servicing. Compatible only with traditional, level 5 surface finishing, not self-leveling, PVA primer systems. **Not for use in wood or tile ceilings.**

WORKFLOW CHART



ELECTRICAL CONTRACTOR

1. Locate and mount housing
2. Screw and lock-in housing
3. Connect wires un housing



DRYWALL CONTRACTOR

1. Install and cut drywall around housing.



ELECTRICAL CONTRACTOR

1. Adjust plaster flange frame and tighten wing nuts.
2. Connect the MR16 and LEDS wiring to the plaster plate.
3. Screw plaster plate into housing.
4. Test MR16 and LEDs.



DRYWALL CONTRACTOR

1. Plaster, sand & paint.
2. Clean aperture with clean damp towel.



ELECTRICAL CONTRACTOR

1. Clean aperture with clean damp towel, where the drywall contractor missed.
2. Adjust pan rotation ring and aim lamp. You're done!

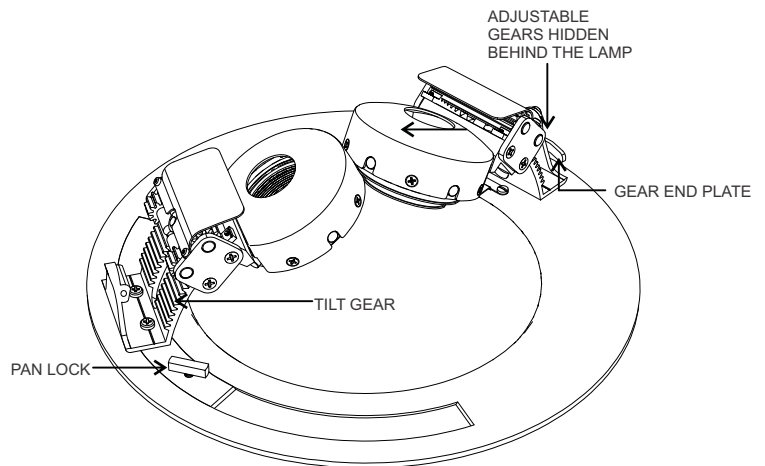
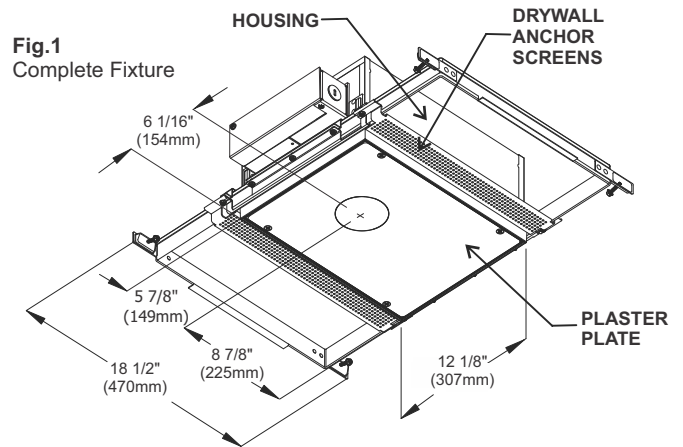

Fig.2
Pan tilt Mechanism attached to inside of plaster plate.

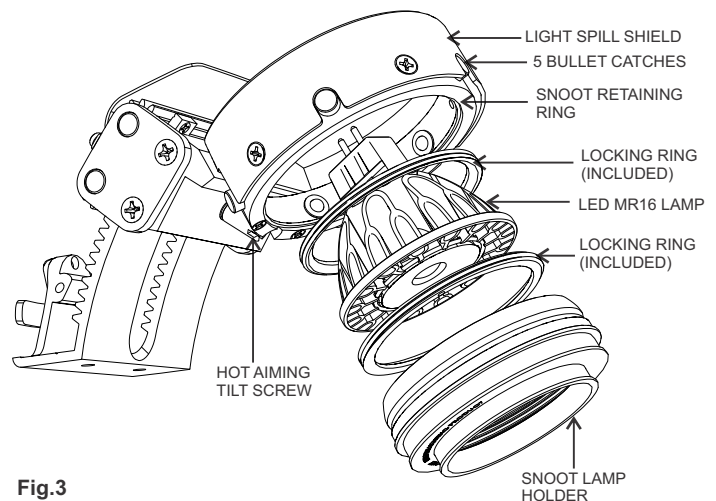

Fig.3
Snoot Assembly



Important

Scan with your mobile device to watch the installation video or visit:

www.purelighting.com/aurora-install

Importante

Escanear con el dispositivo móvil para ver el video de instalación o visite:

www.purelighting.com/aurora-install

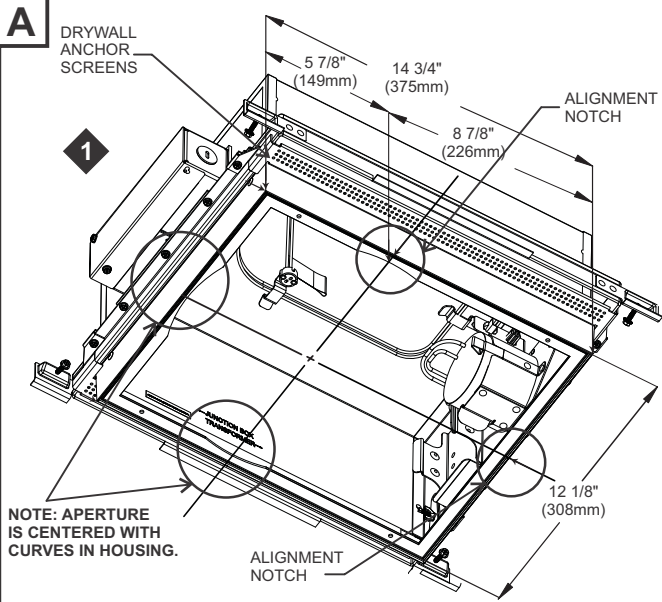

1: Use these dimensions when locating the center point of the aperture during the installation process. Align the fixture using a laser or a chalk line.

NOTE: Drywall anchor screens may be removed, if the joist are less than 14 1/2" apart.

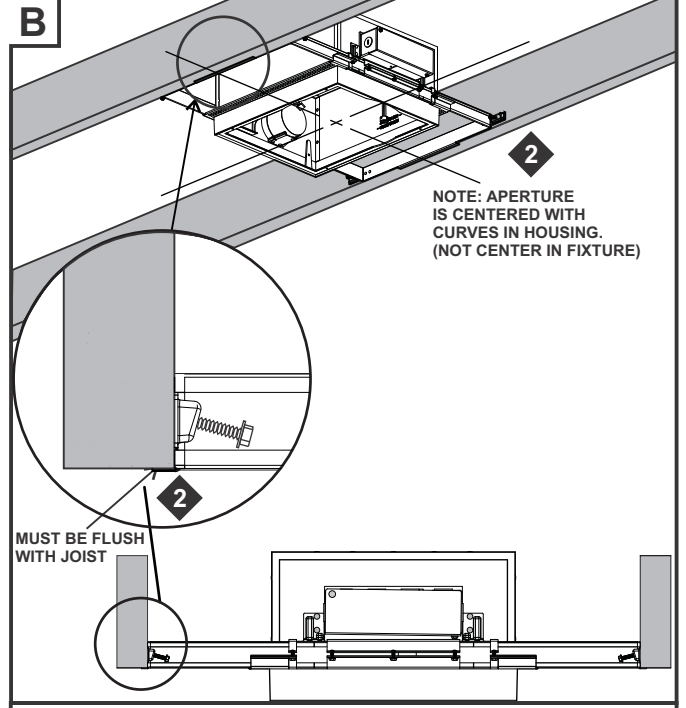

2: Hanger bars must align and remain flush with joist.

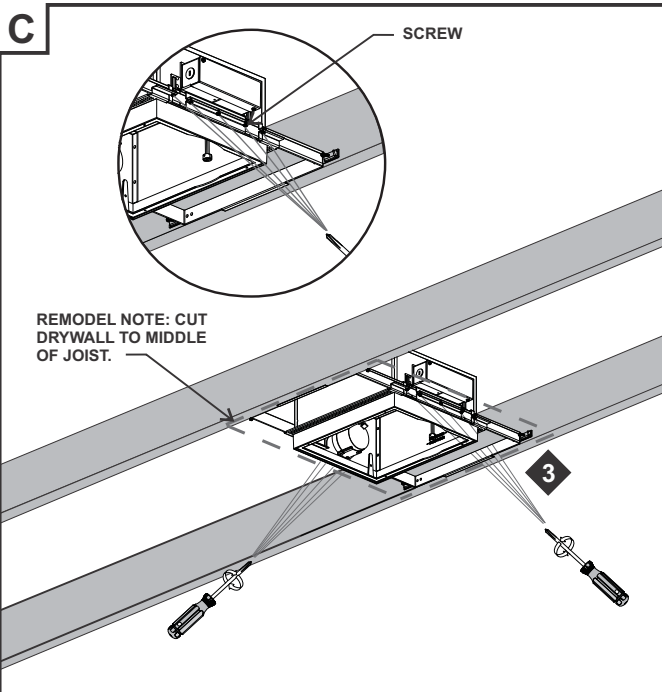

3: After fixture is positioned, tighten all (10) screws on hanger bars.

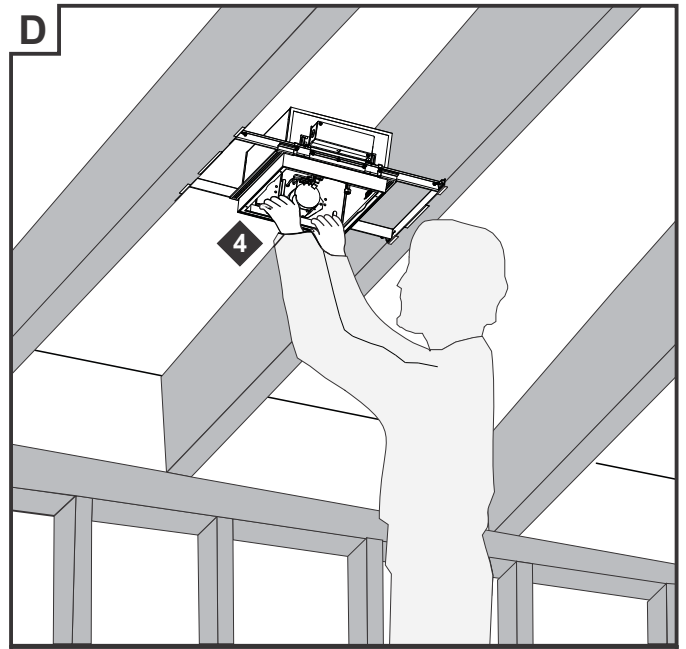

4: After installation, slightly pull on fixture to ensure there is no movement.

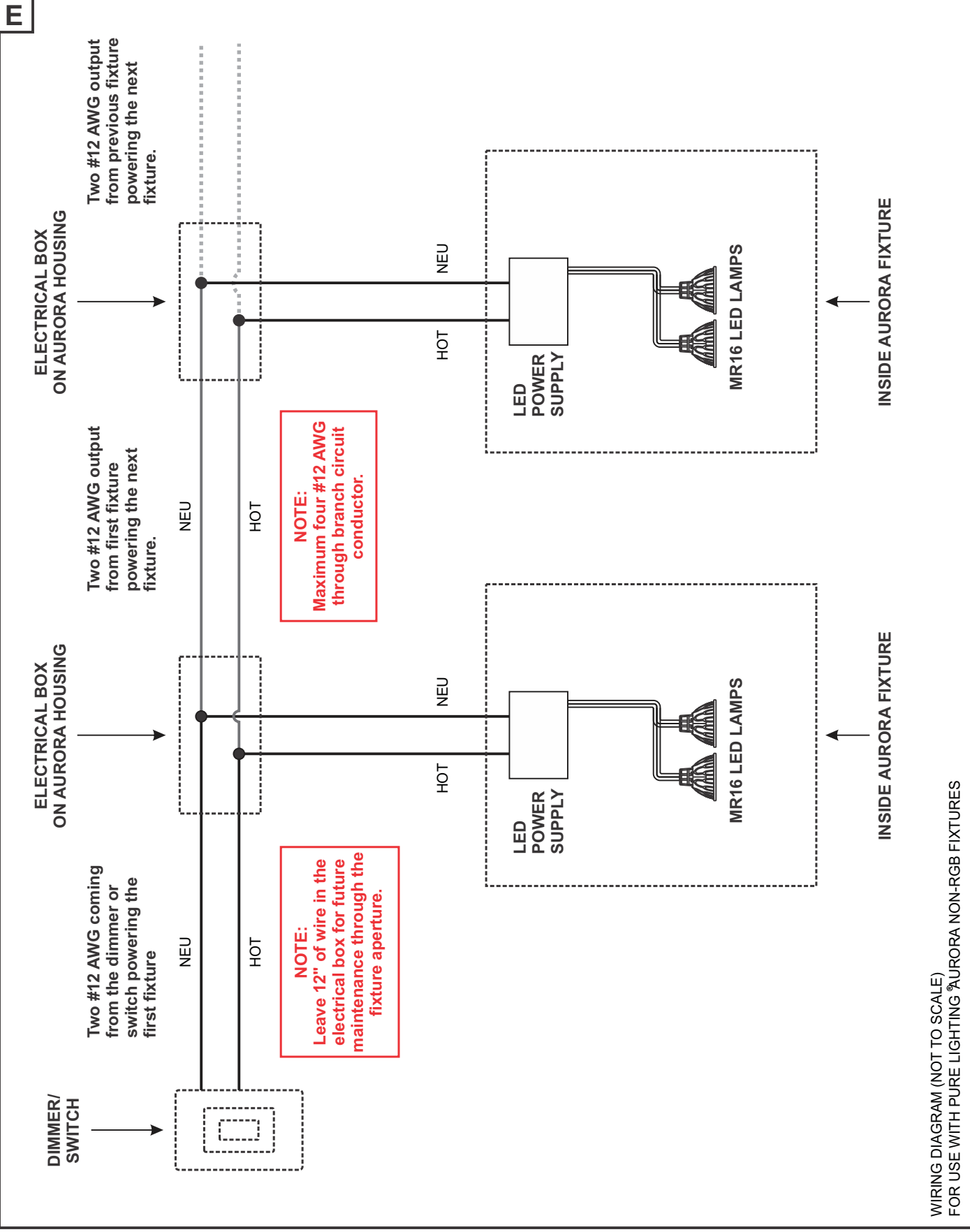

WIRING DIAGRAM (NOT TO SCALE)
FOR USE WITH PURE LIGHTING AURORA NON-RGB FIXTURES

DRYWALL CONTRACTOR

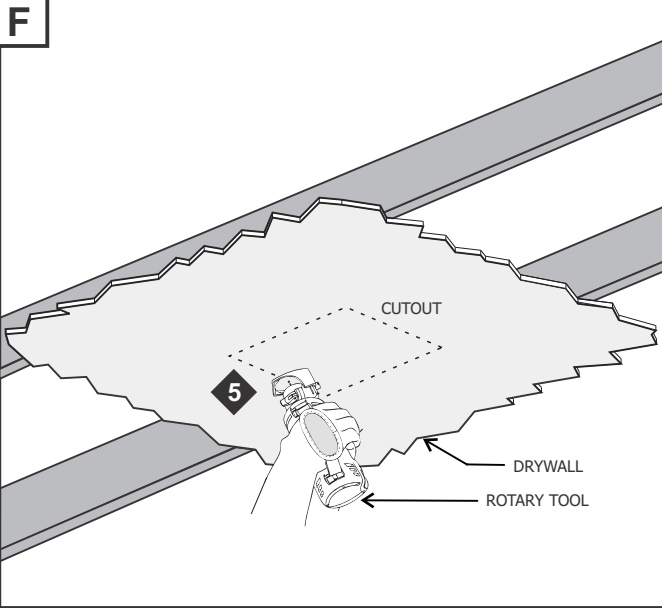

5: Drywall contractor must install drywall and cut 14-3/4" (375mm) X 12-1/8" (308mm) hole with rotary cutting tool around fixture or pre-cut hole in drywall prior to installation.

ELECTRICAL CONTRACTOR

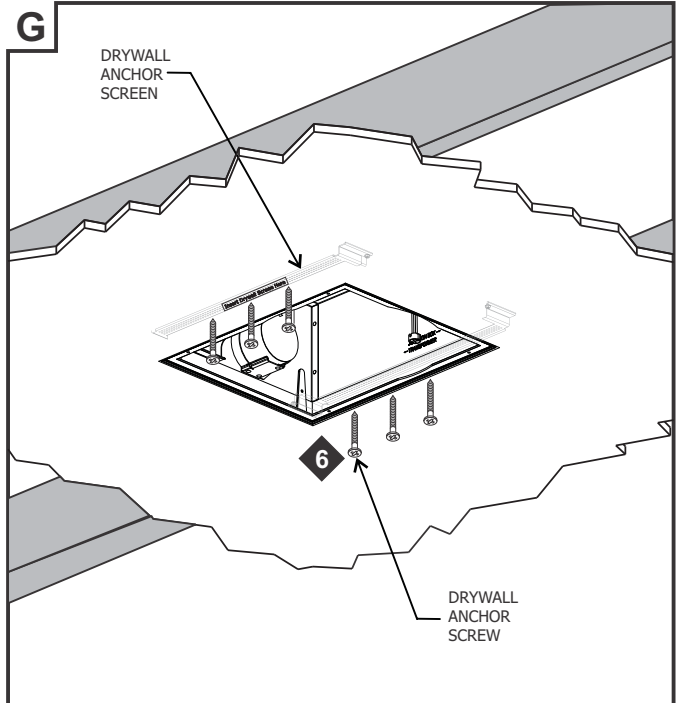

6: Electrician must anchor drywall anchor screens. Insert screws through drywall into anchor screen on fixture.

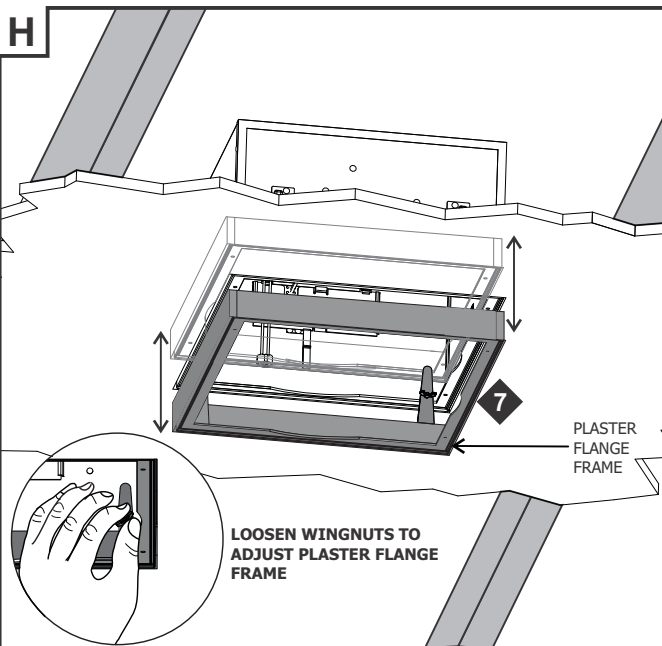

7: Loosen (4) wing nuts and adjust plaster flange frame to be flush with drywall. All 4 corners MUST be exactly even with drywall. Plaster flange frame adjusts to accommodate 1/2" (13mm) to 1-1/4" (32mm) ceiling thickness.

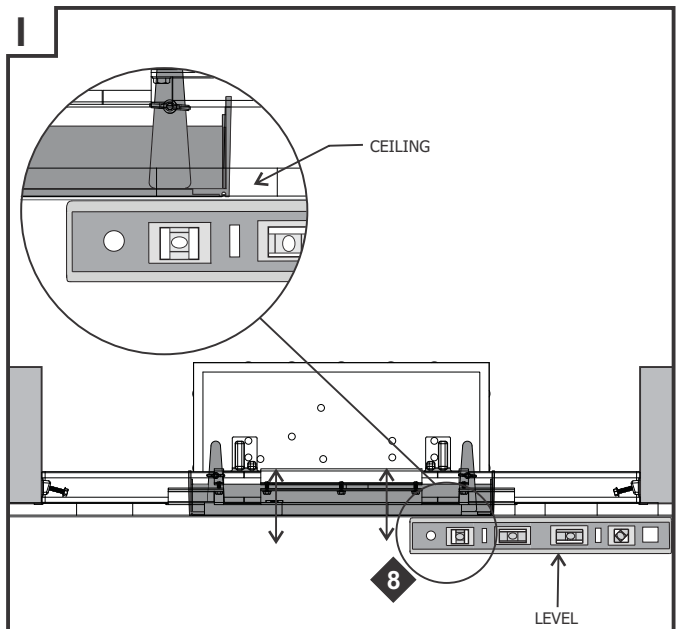

8: Use a straight edge or level and move plaster flange frame up or down to be exactly even with drywall ceiling.



ELECTRICAL CONTRACTOR

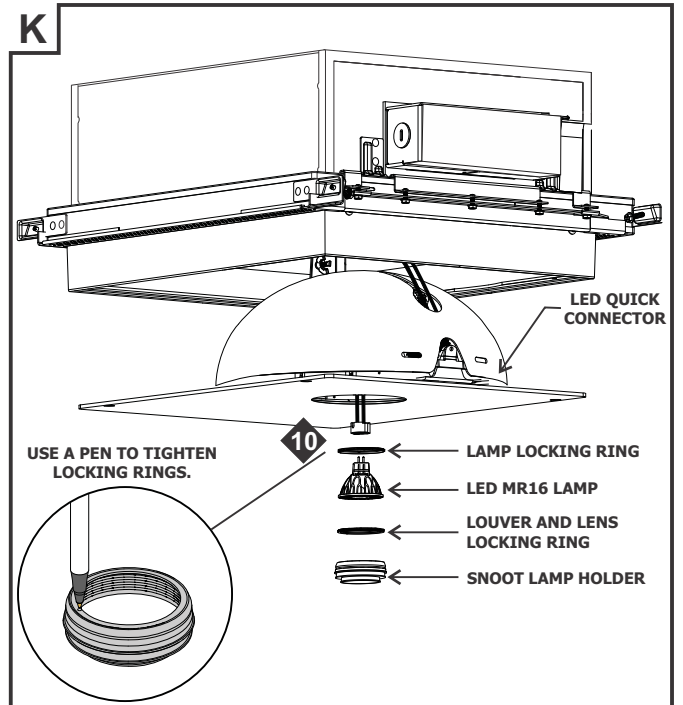
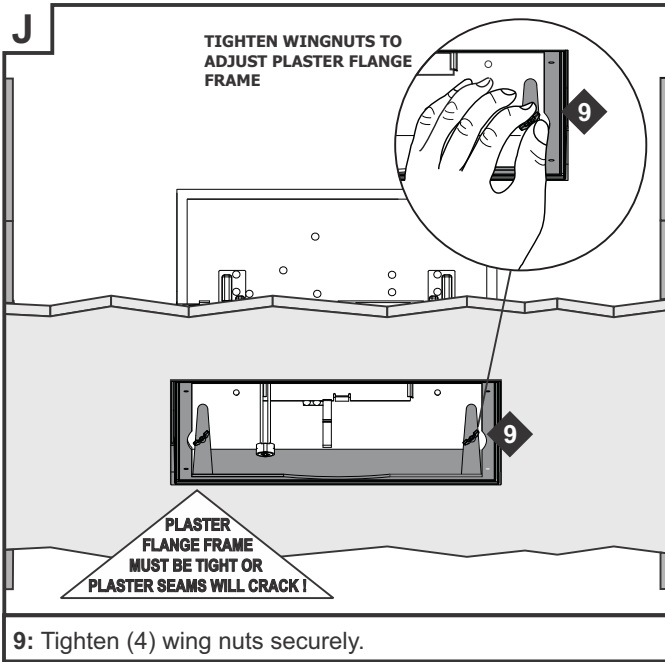

NOTE: Do not use the lens in front of the LED lamp.

10: Assemble lamp holder fixture to MR16 socket. Use a pen to tighten locking rings into place.

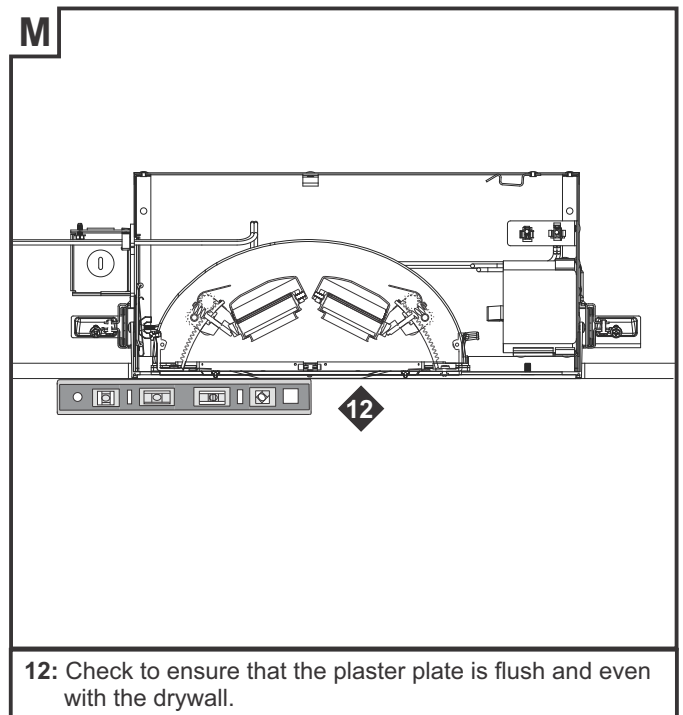
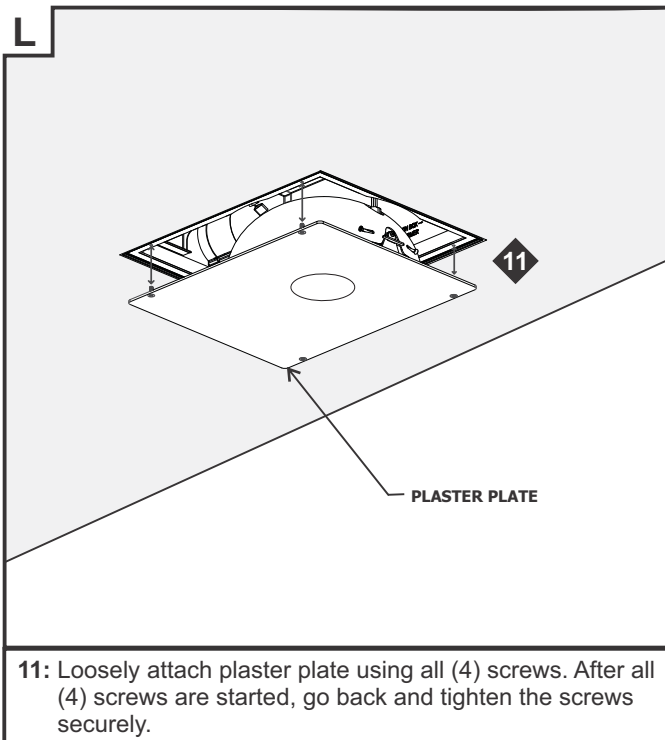



N

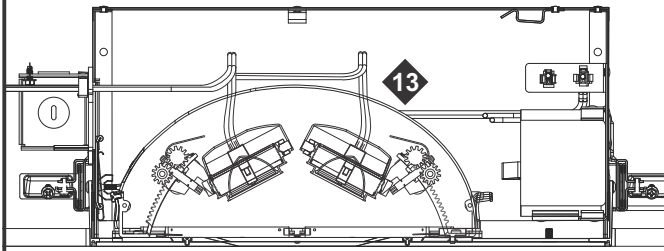

**MR16
LED
ACCENT LIGHT**

13: Turn on and test MR16 LED lamps to ensure they are properly installed.

O

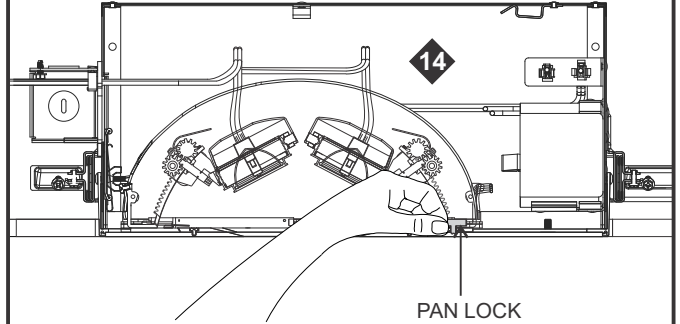

PAN LOCK

HANDS MUST BE CLEAN WHEN ADJUSTING FIXTURE

14: To aim lamp, loosen pan lock, rotate and position the pan rotation ring.

P

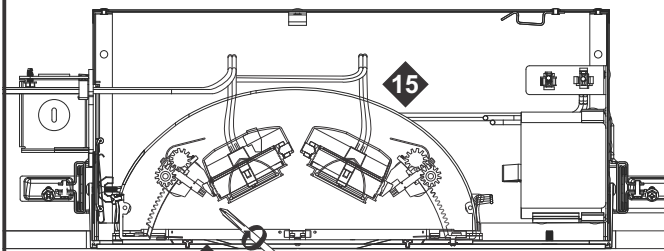

HANDS MUST BE CLEAN WHEN ADJUSTING FIXTURE

15: Tilt and rotate MR16 LED lamp cartridge as needed. When lamp is properly adjusted secure pan lock.

Q

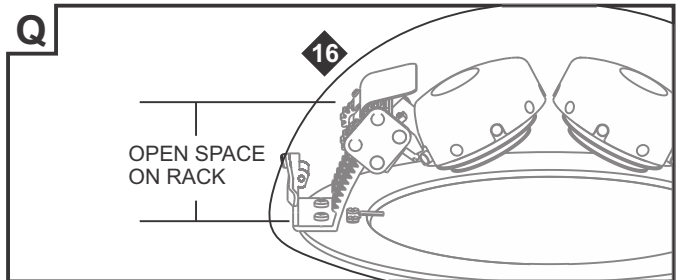

**OPEN SPACE
ON RACK**

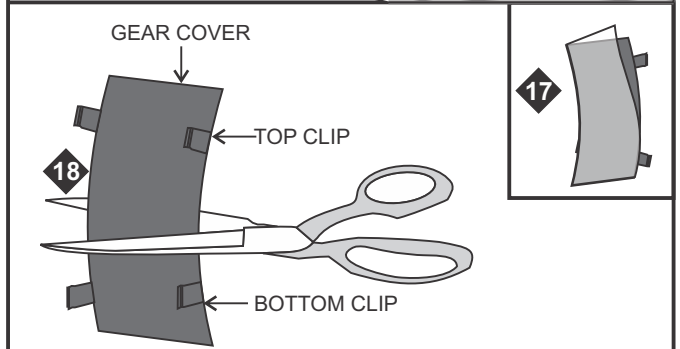

16: Measure the distance of the open space on the track.

17: Remove the protective film from the gear cover.

18: Cut the gear cover to fit the space if necessary.



ELECTRICAL CONTRACTOR

R

19: Insert the gear cover (make sure the gear cover clips are facing the lamp assembly rack) from the bottom of the aperture.

20: Start by snapping the two bottom gear cover clips onto the bottom edge and then snap the top two clips onto the top edge.

DRYWALL CONTRACTOR
 Compatible only with traditional, level 5 surface finishing, not self-leveling, PVA primer systems.

S

21: Apply included Perfect Finish FibaTape Ultra-Thin Drywall Tape around all four sides of the plaster plate. **DO NOT OVERLAP.**

Aplicar incluido Perfect Finish FibaTape Ultra-Thin Tape alrededor de los cuatro lados

T

22: Apply a thin layer of Durabond 45 compound around all four sides of the plaster plate.

Aplique una capa delgada de Durabond 45 compuesto alrededor de todo cuatro lados de la placa de yeso

U

23: Sand plastered surface. Repeat as needed until surface is completely smooth before painting.

Lijar superficie de yeso. Repita según sea necesario hasta que la superficie es totalmente lisa antes de pintar.



ELECTRICAL CONTRACTOR

