

MOBY DICK

SE646P
SE647G

220-240 V.
max 1x70W - E27 (a)
max 1x100W - E27 (b)

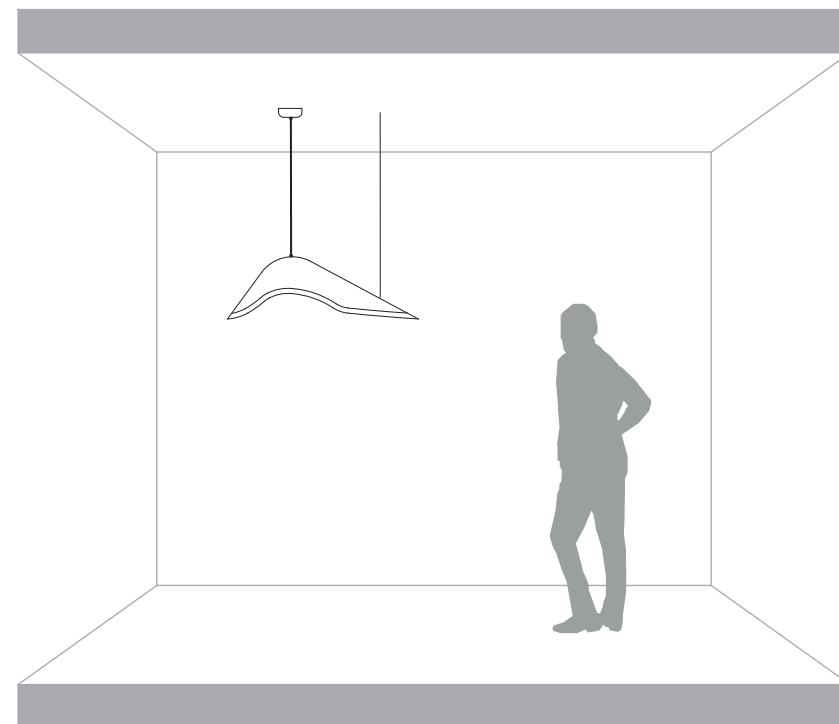
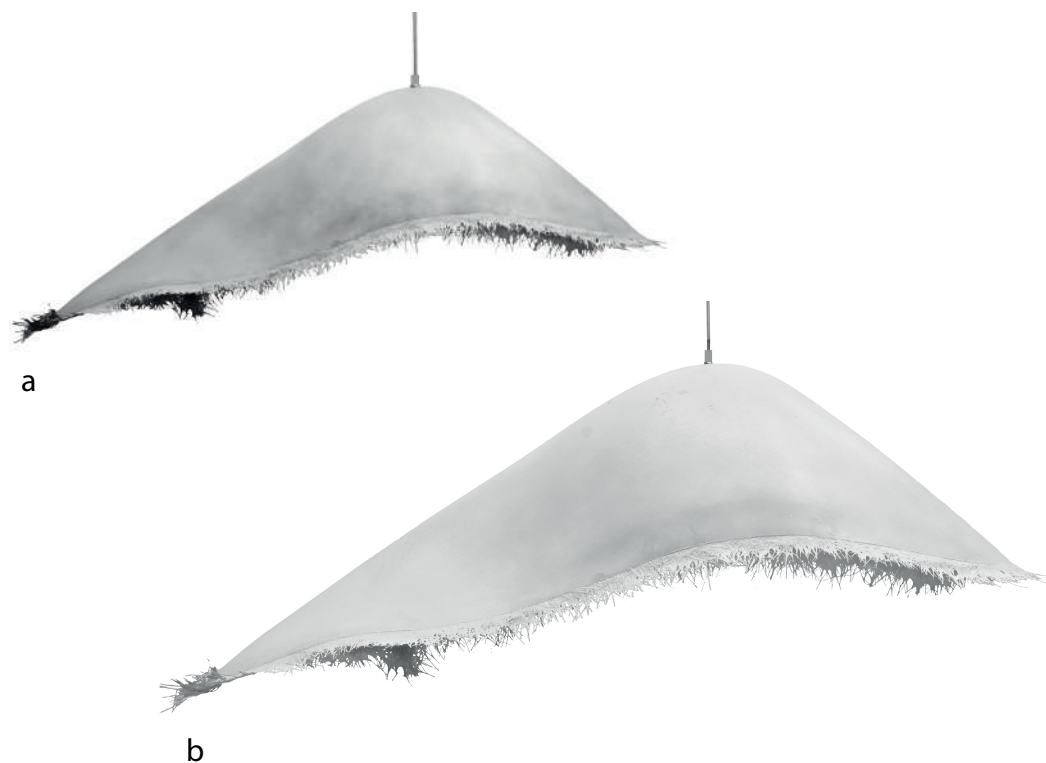

Karman srl

Via A. Grandi, San Martino del piano, 61034 Fossombrone (PU), Italy - p.iva 02175640412 tel +39 0721 71 5042 r.a fax +39 0721 716640 - www.karmanitalia.it

C - 01

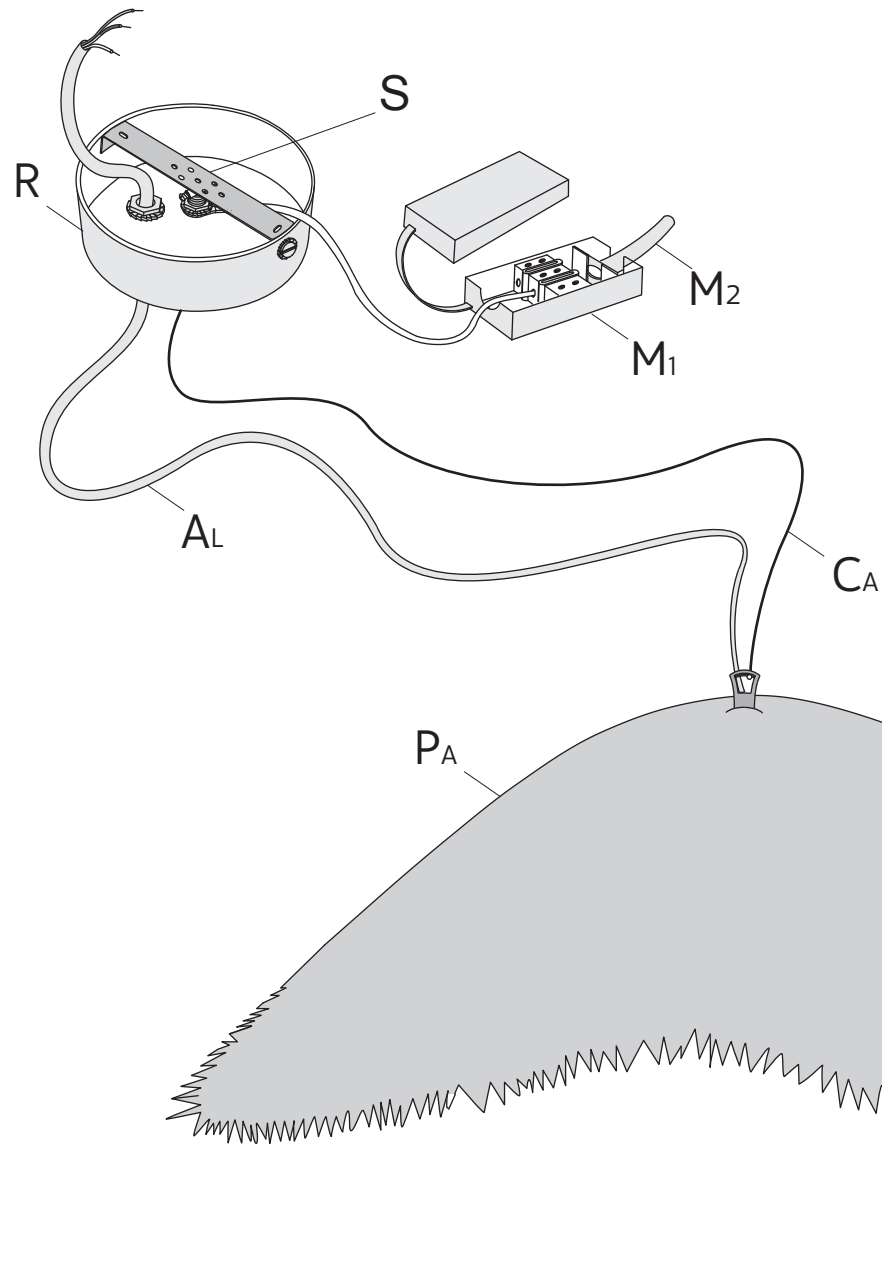

2x **F**

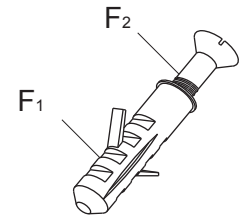

1x **B**

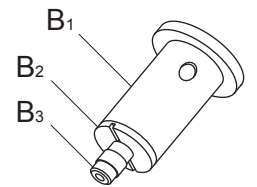

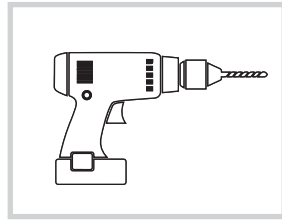
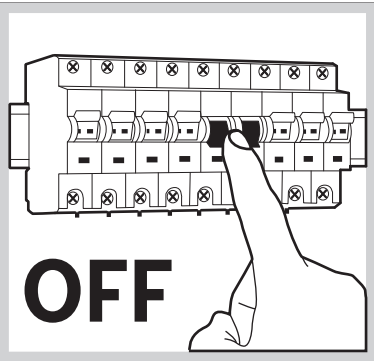

1

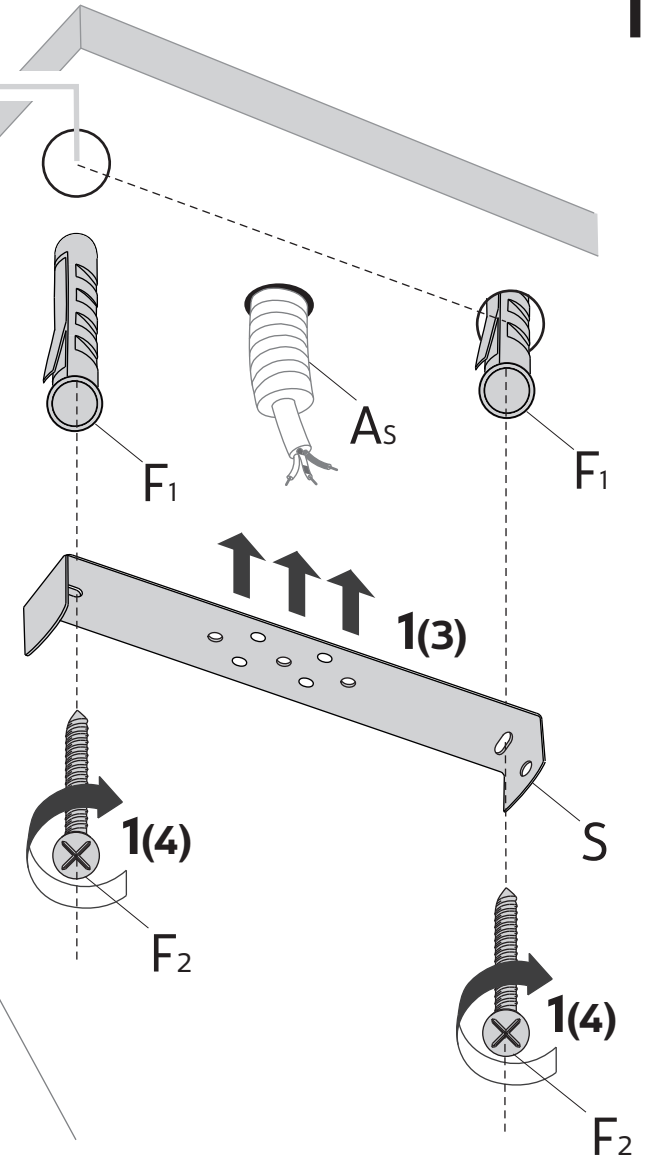
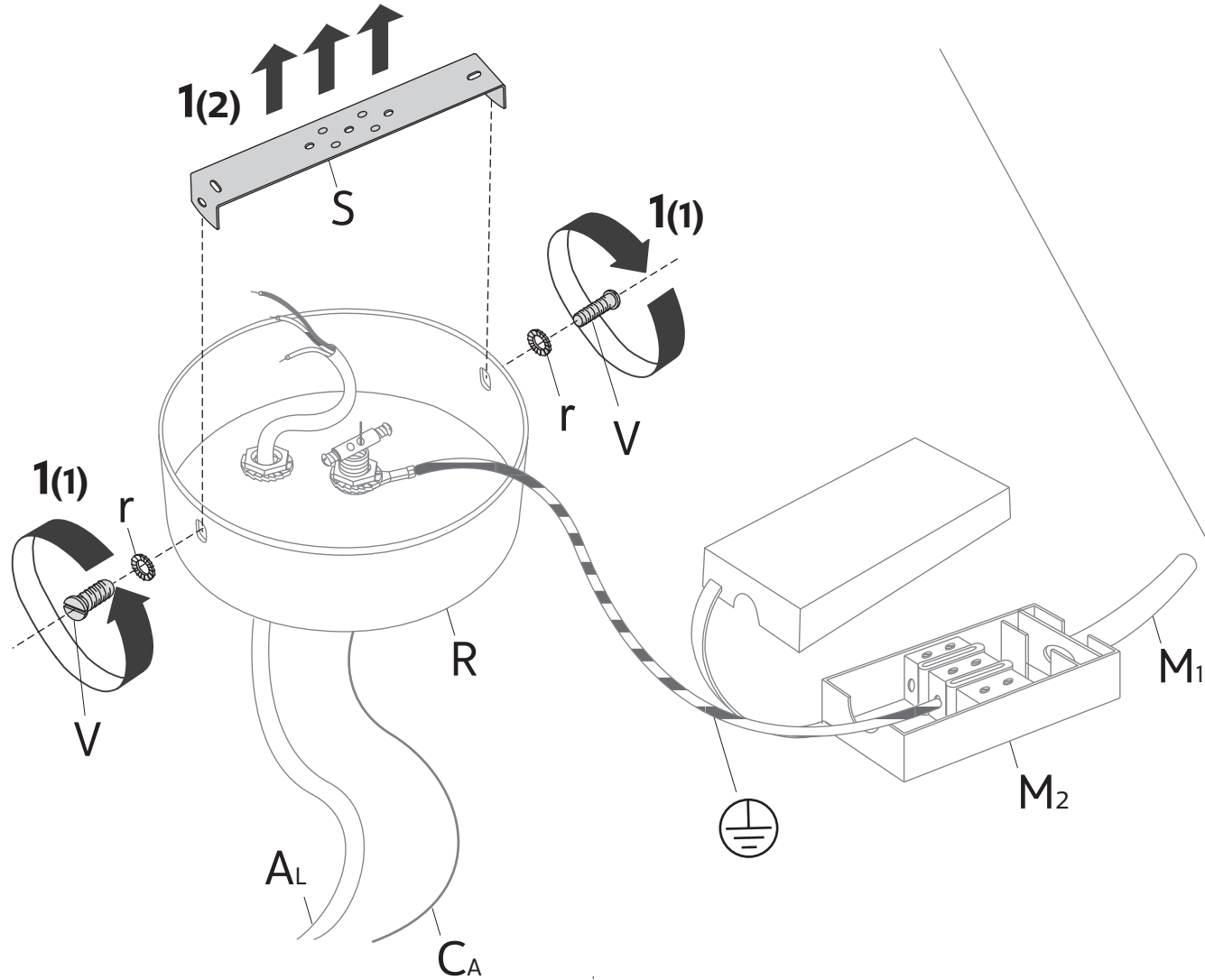

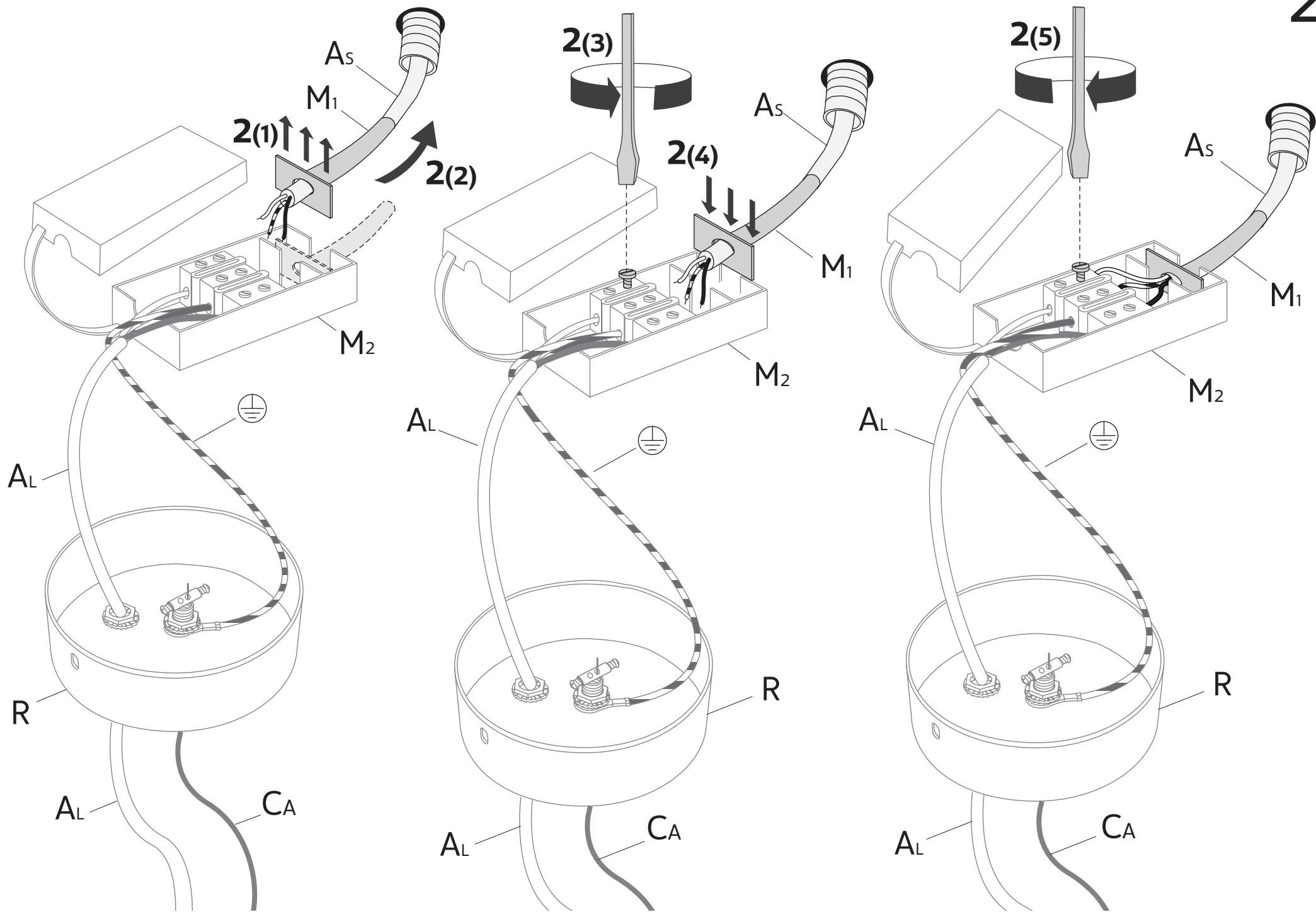

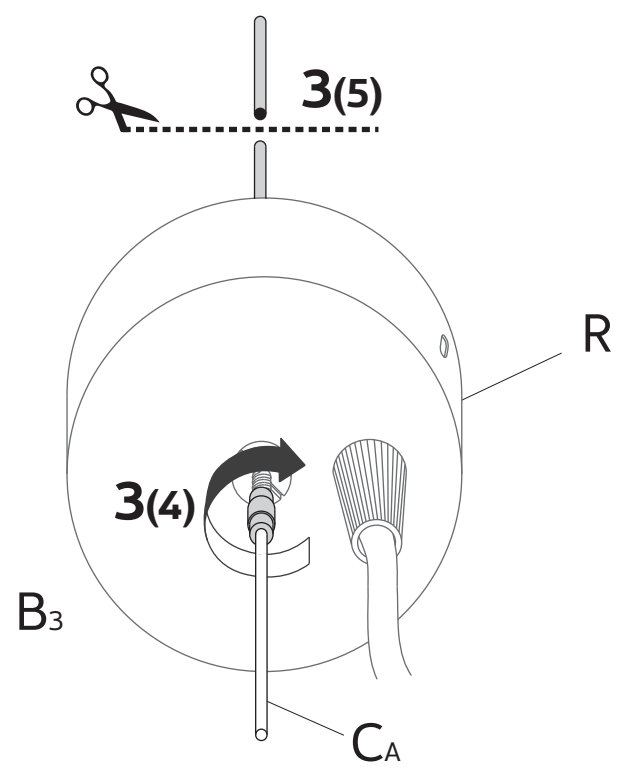
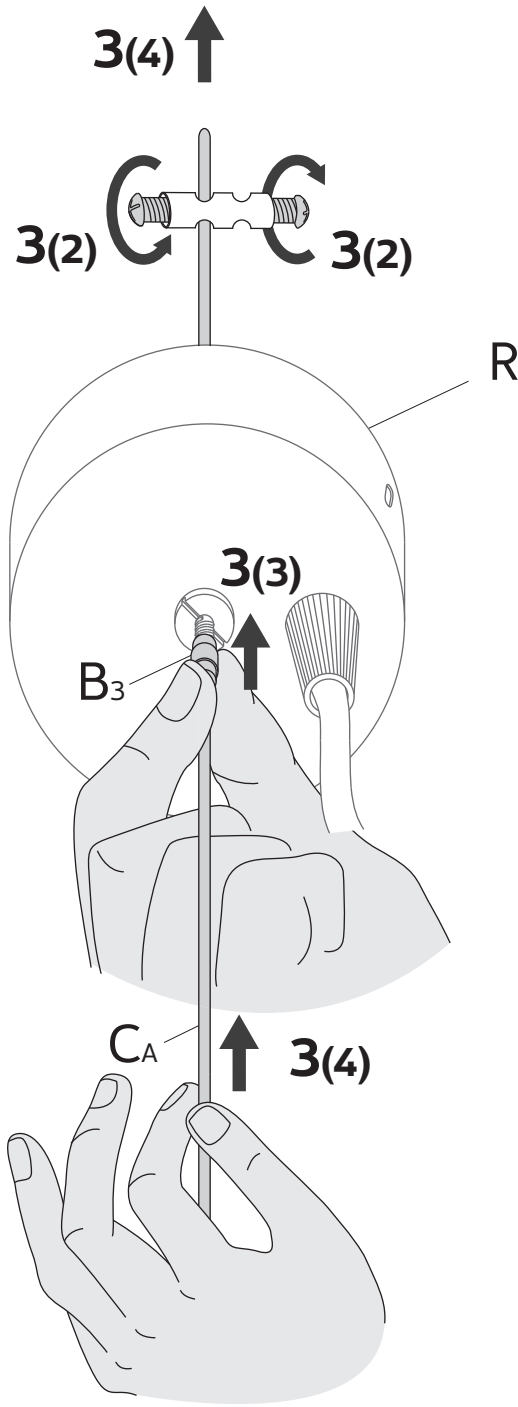
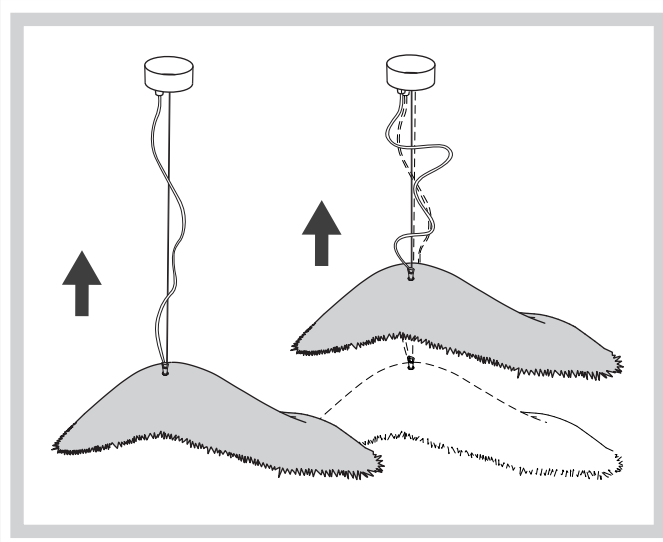

3

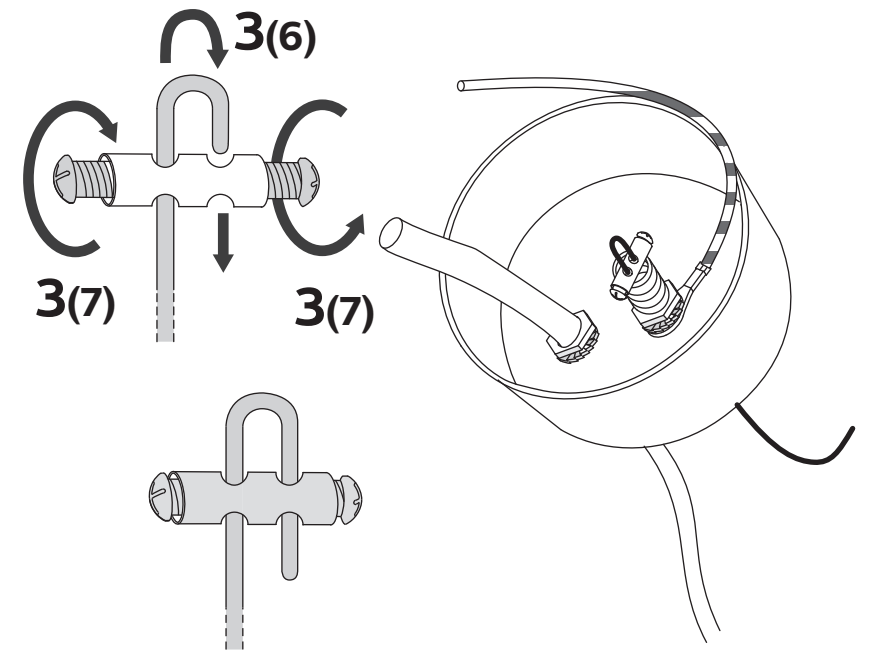
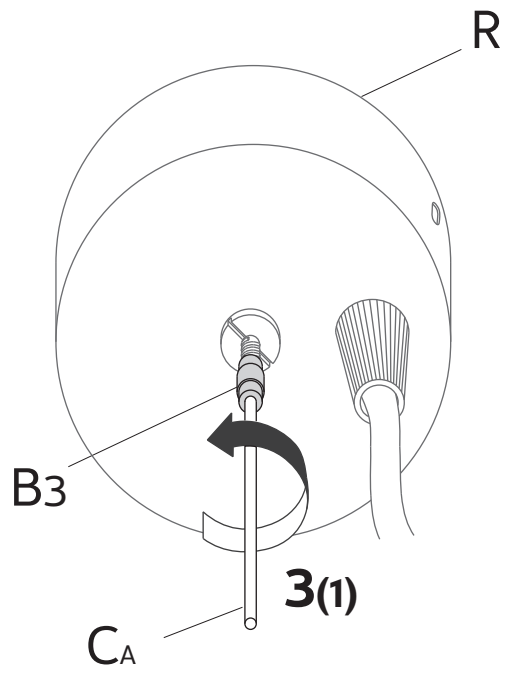

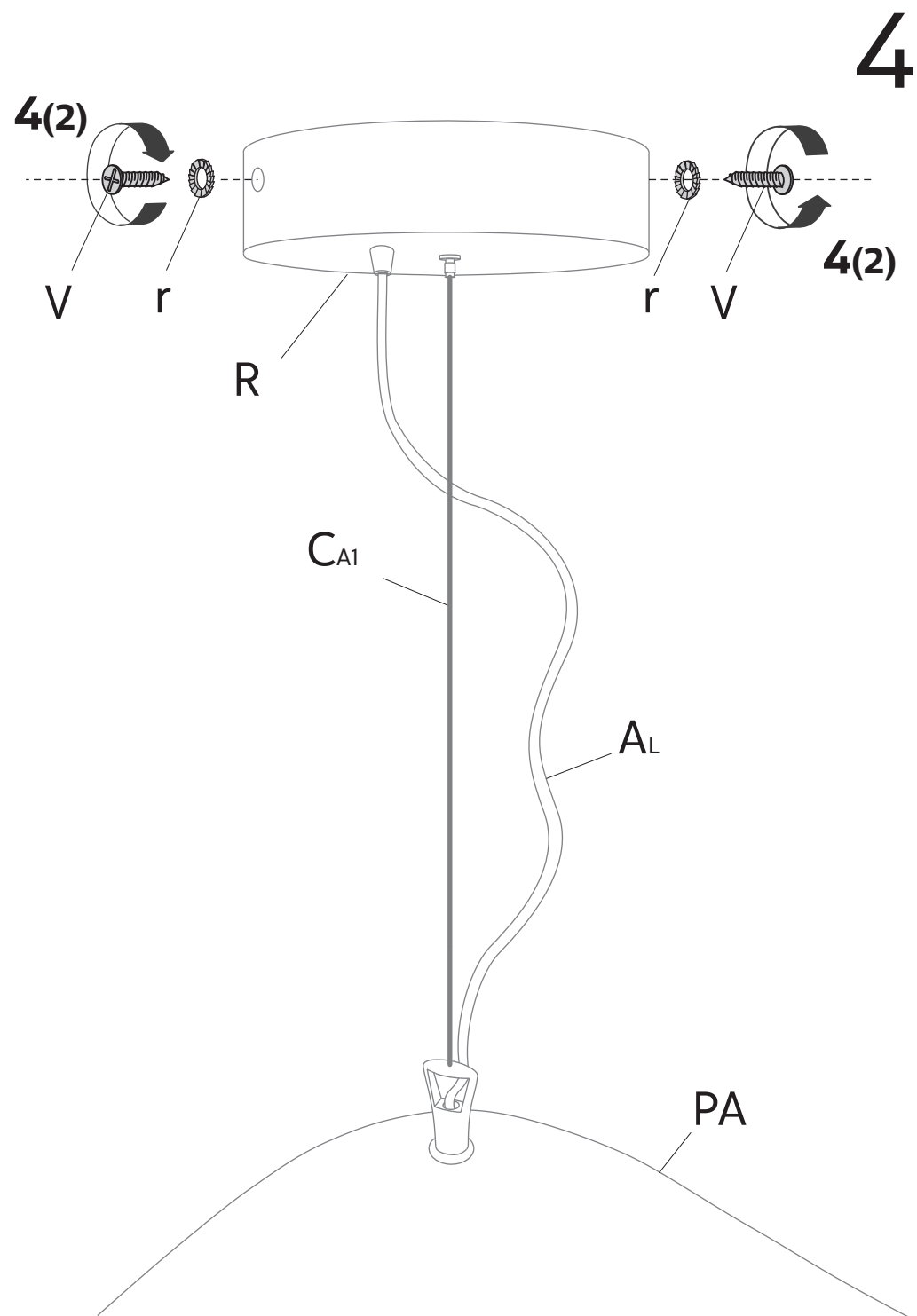
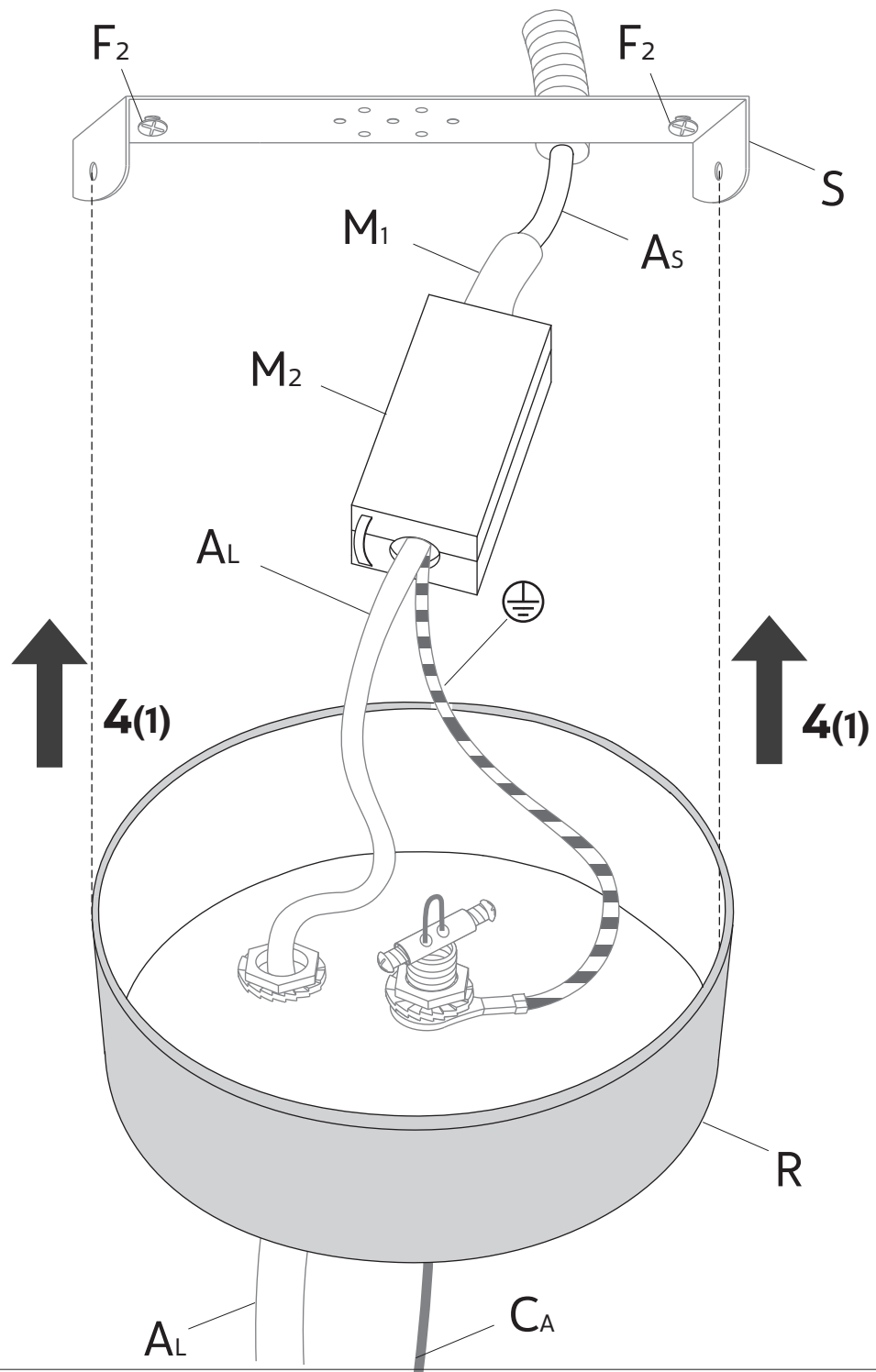

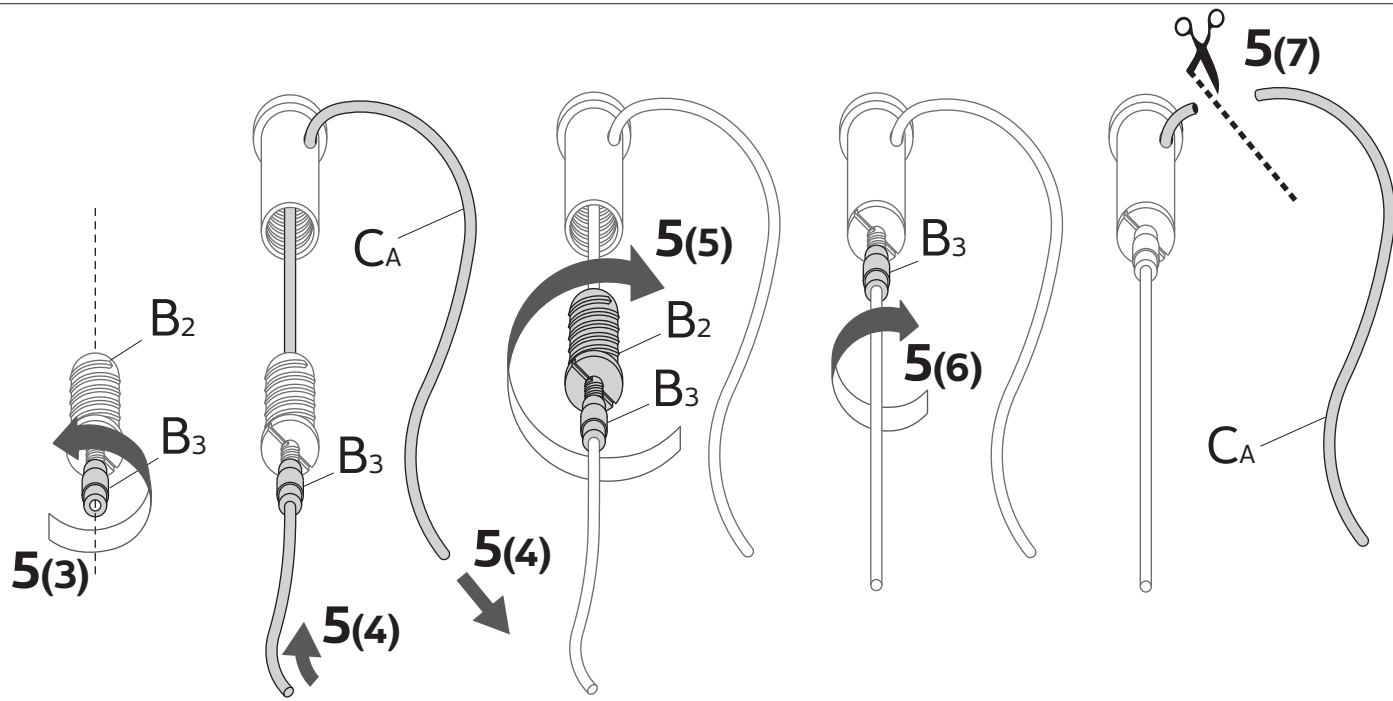
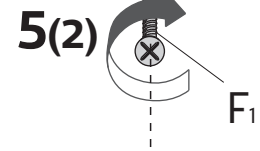
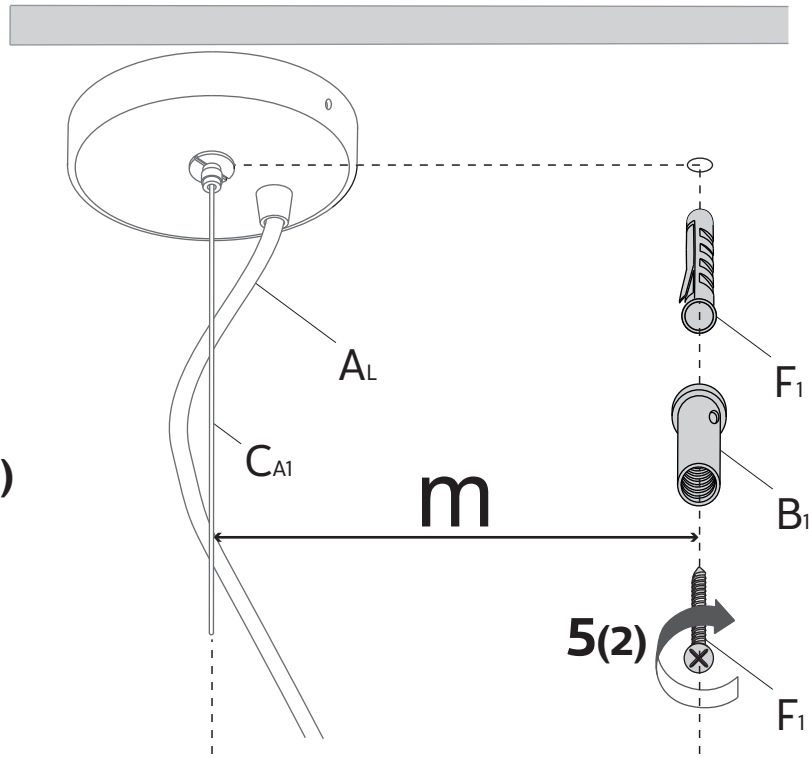
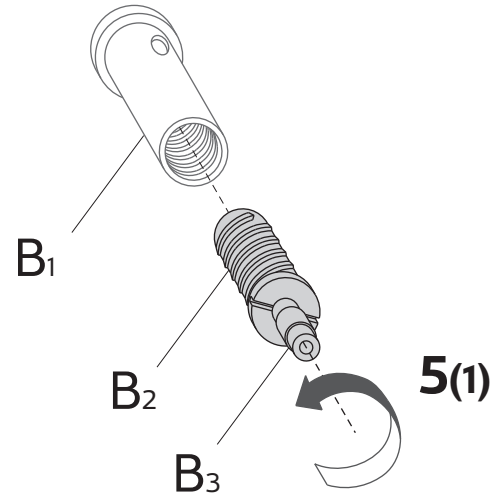
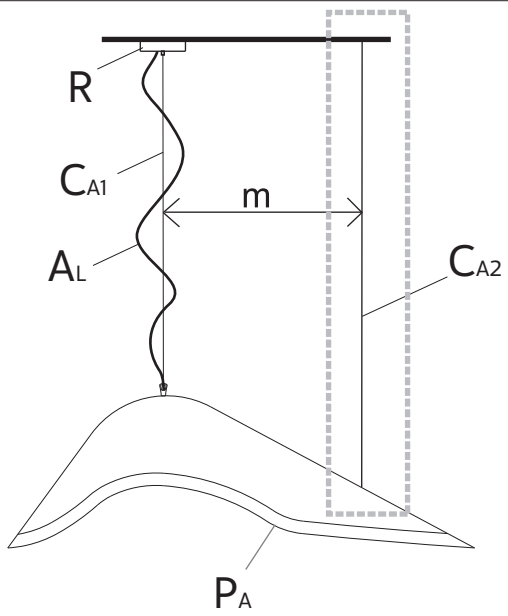

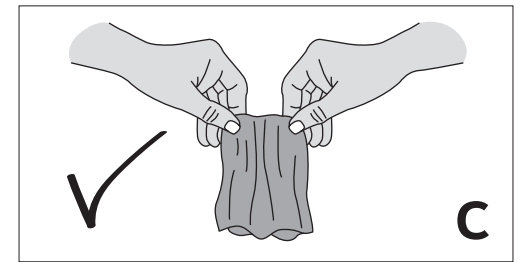
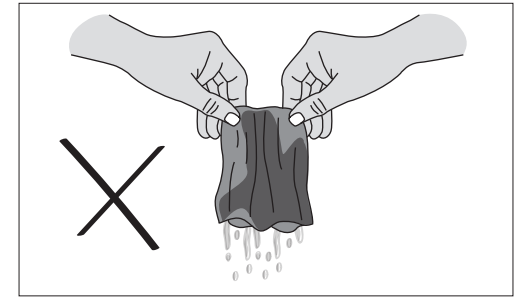
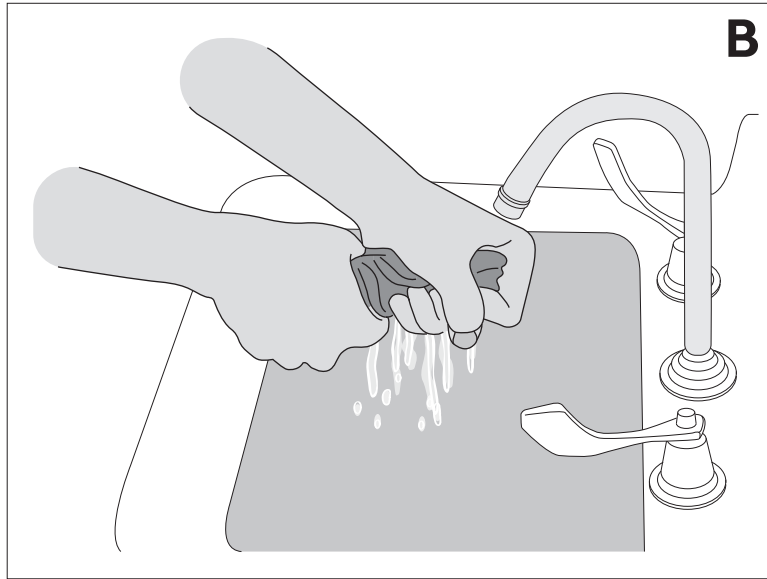
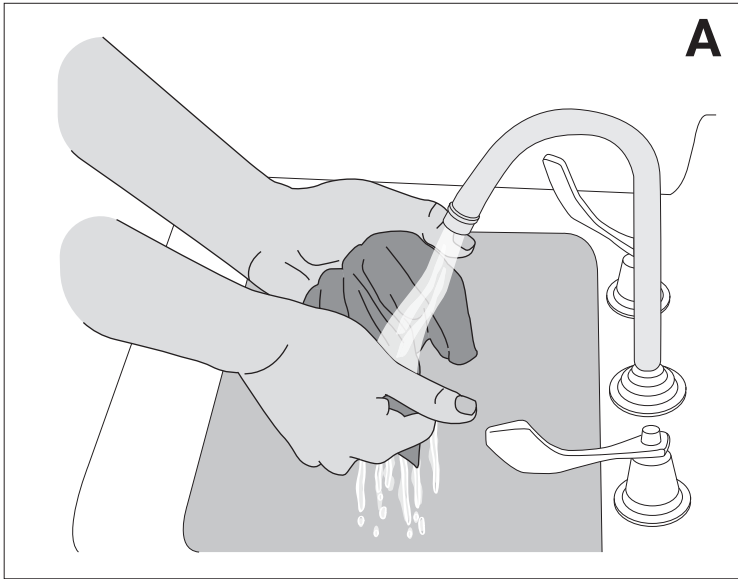



chemical agents



chemical agents



alcohol

