

Stagger 48, 72, 260, and 284 Linear Suspension

700LSSTG48, 700LSSTG72, 700LSSTG260, 700LSSTG284 | 1.0



GENERAL PRODUCT INFORMATION:

These fixtures are intended to be installed utilizing NEC compliant junction boxes.



This product is suitable for damp locations.

Dimmable with most LED compatible ELV, TRIAC and 0-10V dimmers.

CAUTION - RISK OF FIRE
 This product must be installed in accordance with the applicable installation code by a person familiar with the construction and operation of the product and the hazards involved.
Use minimum 90°C supply conductors.

SAVE THESE INSTRUCTIONS!

Install the Fixture

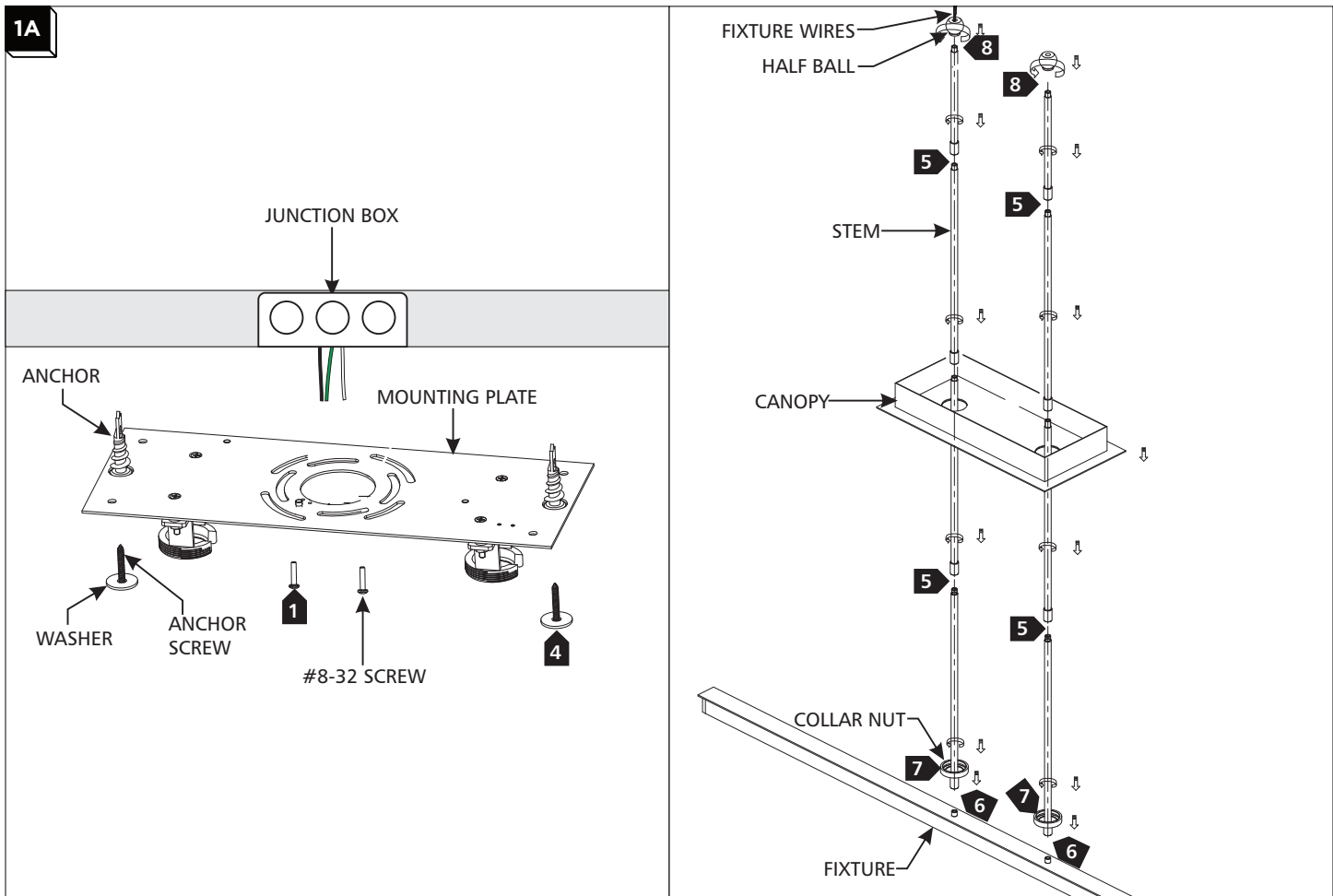

- 1** Secure the mounting plate to the electrical box with the #8-32 screws provided.
- 2** Line up an anchor with the center of a mounting plate hole and push the anchor in up to the threads.
- 3** Screw the anchor the rest of the way in with a screwdriver.
- 4** Secure the mounting plate to the anchor with an anchor screw and washer. Repeat steps 2-4 for the remaining anchors.

- 5** Determine the desired height of the fixture using the provided stems and assemble two separate sets by screwing them together.
- 6** Feed the fixture wires through one of the stem assemblies and screw them to the top of the fixture.
- 7** Slide a collar nut, thread side up, onto each stem, followed by the canopy.
- 8** Screw a half ball onto each stem top.

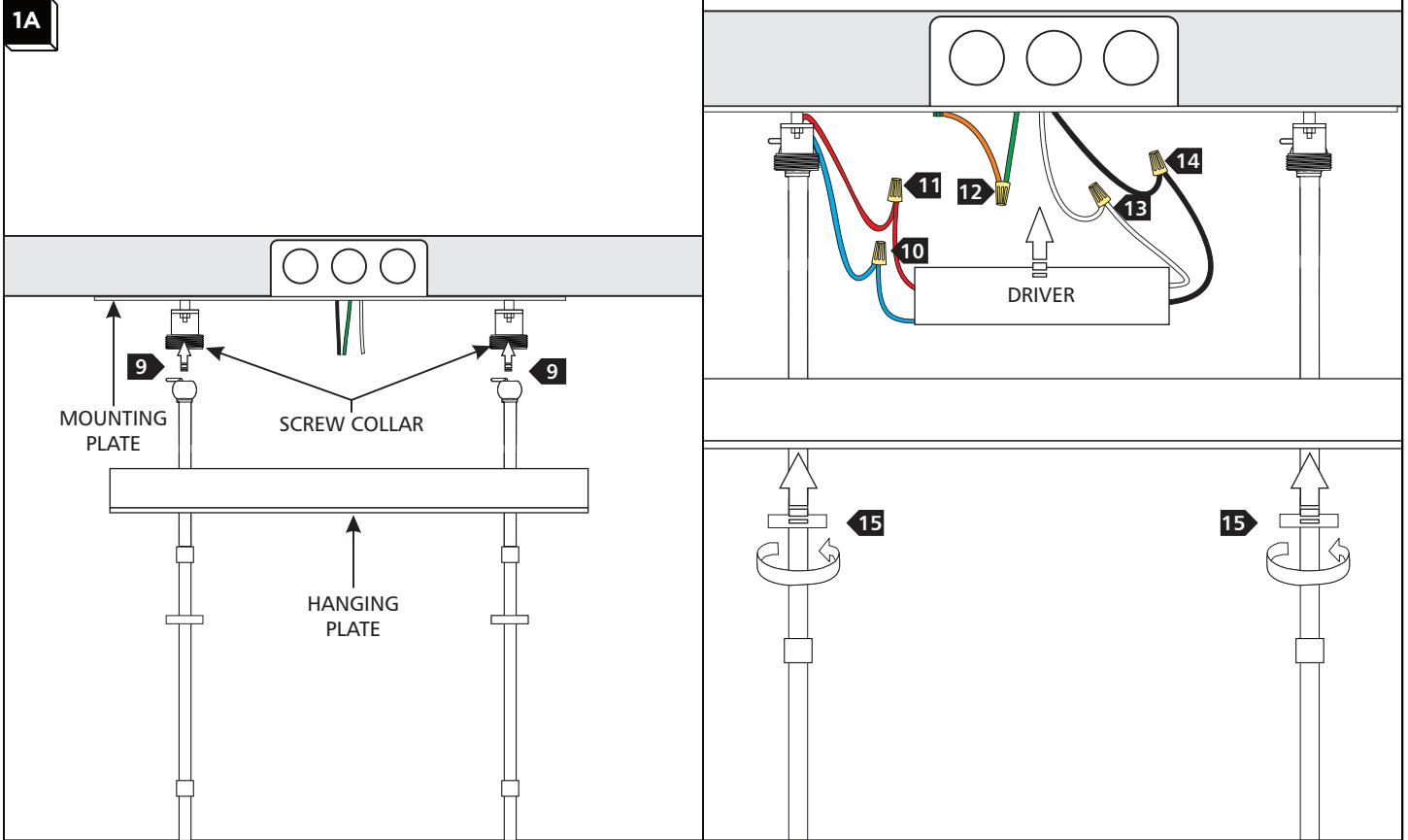

- 9** Insert the half ball/stem assemblies through the hanging plate and slide the half ball into the screw collars.
- 10** Connect the negative (-) fixture wire to the negative (-) output driver wire with a wire nut.
- 11** Connect the positive (+) fixture wire to the positive (+) output driver wire with a wire nut.
- 12** Connect the fixture to a suitable ground in accordance with local electrical codes.
- 13** Connect the white input driver wire to the neutral power line wire with a wire nut.
- 14** Connect the black input driver wire to the hot power line wire with a wire nut.
- 15** Neatly place the driver, all wires, and wire nut connections inside the mounting plate, place hanging plate onto the mounting, and secure in place by screwing all of the collar nuts onto the screw collars.

 **TECH LIGHTING**

7400 Linder Ave., Skokie, IL 60077
 T 847.410.4400 | F 847.410.4500
www.techlighting.com