

Jaxon Bath (LED)

700BCJXN24_-LED

1.1



GENERAL PRODUCT INFORMATION:



These fixtures are intended to be installed utilizing NEC compliant junction boxes.

This product is dimmable with a low-voltage electronic dimmer.

This product is suitable for damp locations.

CAUTION - RISK OF FIRE
 This product must be installed in accordance with the applicable installation code by a person familiar with the construction and operation of the product and the hazards involved.
 Use minimum 90°C supply conductors.

Install the Backplate

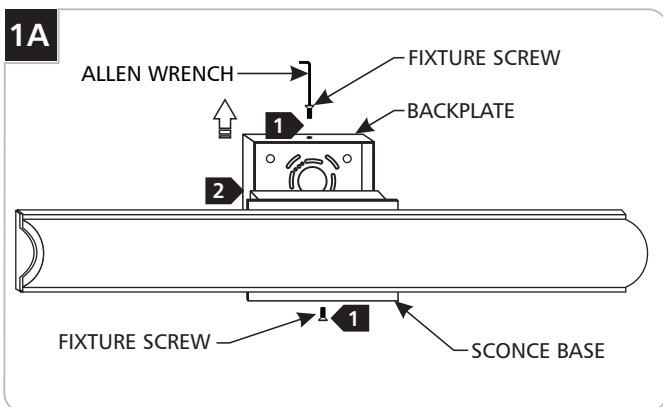

- 1** Remove the two fixture screws with the provided Allen wrench.
- 2** Remove the backplate from the sconce base.

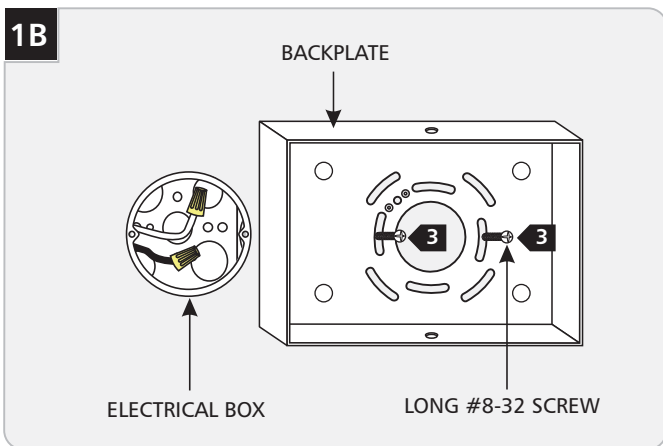

- 3** Temporarily mount the backplate to the electrical box with two long #8-32 screws.

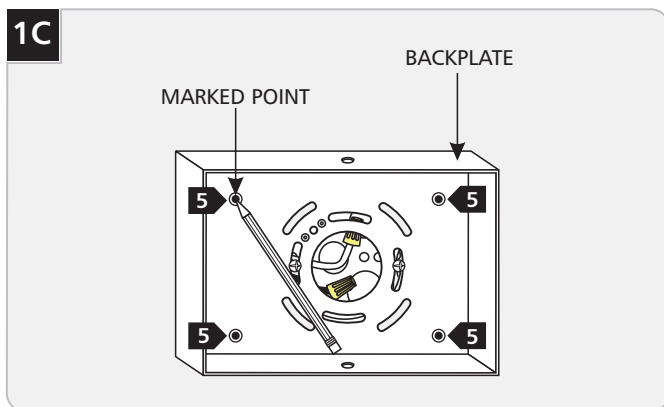

- 4** Verify that the backplate is leveled before continuing.
- 5** Mark the four anchor locations.

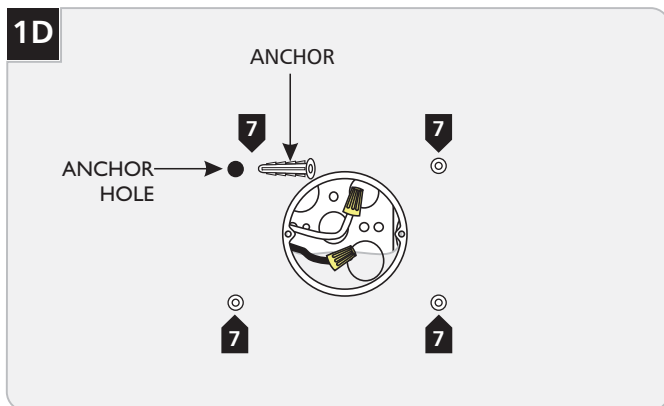

- 6** Remove the backplate and drill appropriate sized holes at the marked points.
- 7** Install the anchors into the drilled holes.

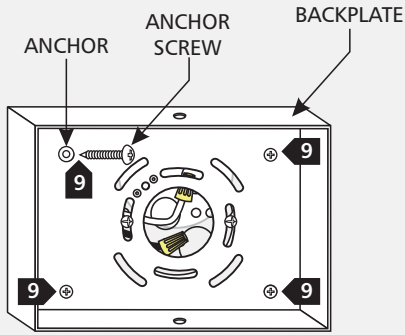
1E

- 8** ▶ Reinstall the backplate.
- 9** ▶ Screw the anchor screws into the anchors.

Install the Shade

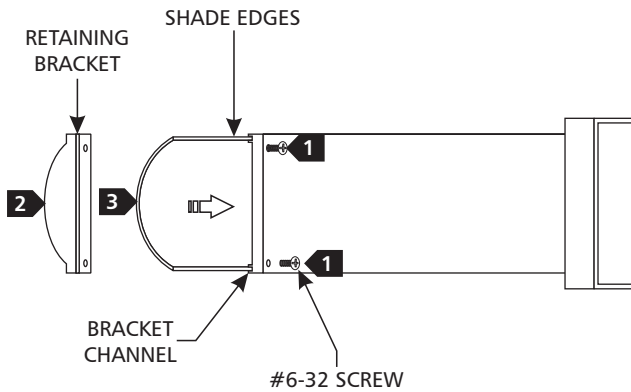
2A

- 1** ▶ Remove the two #6-32 screws behind the retaining bracket.
- 2** ▶ Remove the retaining bracket.
- 3** ▶ Carefully slide the shade edges into the bracket channels.
- 4** ▶ Replace the retaining bracket and tighten the two #6-32 screws.

Connect the Power

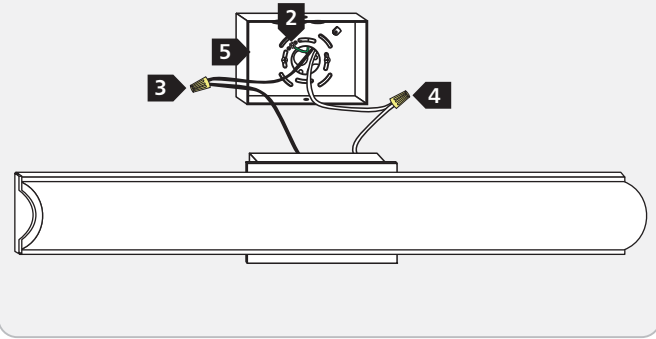
3A

- 1** ▶ Connect the backplate to a suitable ground according to local electrical codes.
- 2** ▶ Connect the black driver wire to the hot power line wire with a wire nut.
- 3** ▶ Connect the white driver wire to the neutral power line wire with a wire nut.
- 4** ▶ Properly place all wires into the backplate, mount the fixture by sliding it back onto the backplate, and re-installing the fixture screws (reversal of step 1A).

SAVE THESE INSTRUCTIONS!



TECH LIGHTING®

7400 Linder Ave, Skokie, IL 60077
847.410.4400

www.techlighting.com

© 2016 Tech Lighting, L.L.C. All rights reserved. The "Tech Lighting" graphic is a registered trademark of Tech Lighting, L.L.C. Tech Lighting reserves the right to change specifications for product improvements without notification.

A Generation Brands Company