

# Metro (LED)

700BCMET\_LED

1.1



## GENERAL PRODUCT INFORMATION:



Lamp power consumption is rated at 20 watts at 12 volts.

This product is suitable for indoor damp locations.

This product can mount to either a 4" square electrical box with round plaster ring or an octagon electrical box.

This product is dimmable with a low-voltage electronic dimmer.

This product is suitable for damp locations.

**CAUTION:** Do not use chemical cleaning products on LEDs. To clean, wipe gently with a clean, dry cloth.



### CAUTION - RISK OF FIRE

This product must be installed in accordance with the applicable installation code by a person familiar with the construction and operation of the product and the hazards involved.

Use minimum 90°C supply conductors.

## Install the Backplate

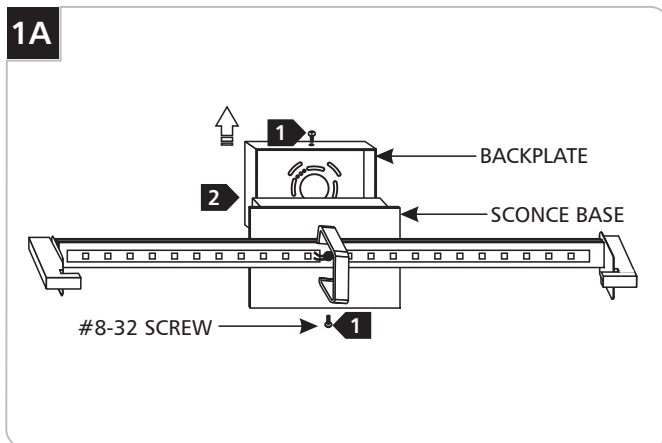

**CAUTION:** When handling the fixture, do not apply pressure to the LEDs. Hold the fixture by the sconce base only.

- 1 Remove the two #8-32 screws on the backplate with a Phillips head screwdriver.
- 2 Remove the backplate from the sconce base.

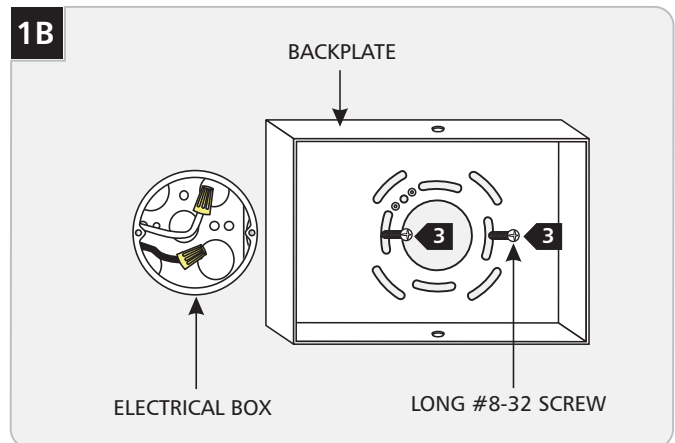

- 3 Mount the backplate to the electrical box with two long #8-32 screws.

## Connect the Power

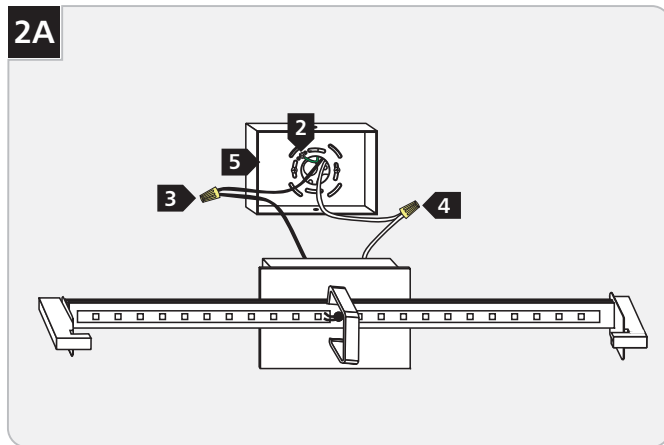

- 1 Connect the backplate to a suitable ground according to local electrical codes.
- 2 Connect the black driver wire to the hot power line wire with a wire nut.
- 3 Connect the white driver wire to the neutral power line wire with a wire nut.
- 4 Properly place all wires into the backplate.

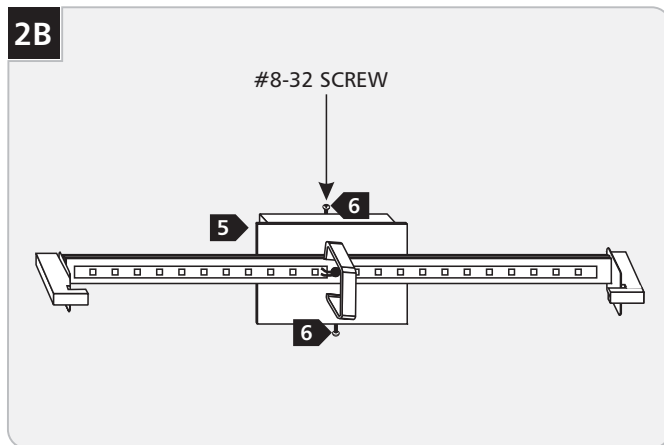

- 5 Place the sconce base onto the backplate and align the holes.
- 6 Replace and tighten the #8-32 screws.

## Install the Shades

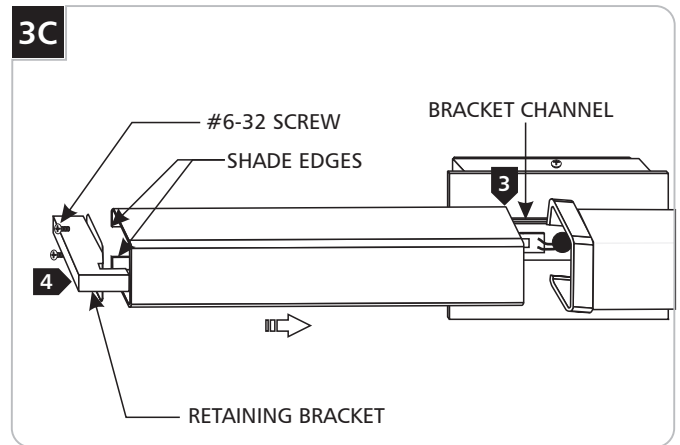

- 1 Remove the two #6-32 screws on side of the retaining bracket.
- 2 Remove the retaining bracket.
- 3 Carefully slide the shade edges into the bracket channels.
- 4 Replace the retaining bracket and tighten the two #6-32 screws.

**SAVE THESE INSTRUCTIONS!**



7400 Linder Ave, Skokie, IL 60077  
847.410.4400

[www.techlighting.com](http://www.techlighting.com)

© 2012 Tech Lighting, L.L.C. All rights reserved. The "Tech Lighting" graphic is a registered trademark of Tech Lighting, L.L.C. Tech Lighting reserves the right to change specifications for product improvements without notification.

A Generation Brands Company