

# peleloles

Design by  
Boris Klimek

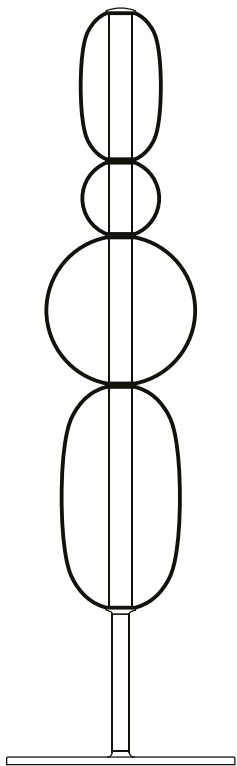

bomma

[bomma.cz](http://bomma.cz)

TECHNICAL SHEET

# PEBBLES

## floor lamp large

Design by  
Boris Klimek

### Handmade glass attributes

All Bomma products are hand-made from mouth-blown lead-free crystal. Therefore any small bubbles, non-melts and irregularities in the glass are both proof and a characteristic feature of this traditional craft.

The Pebbles Collection is made by underlying colored glass technology. Thanks to the manual process of blowing underlay glass, each piece is an original. Individual products may vary slightly in intensity, hue or even color. This is an accompanying characteristic of the traditional underlay glass technology.

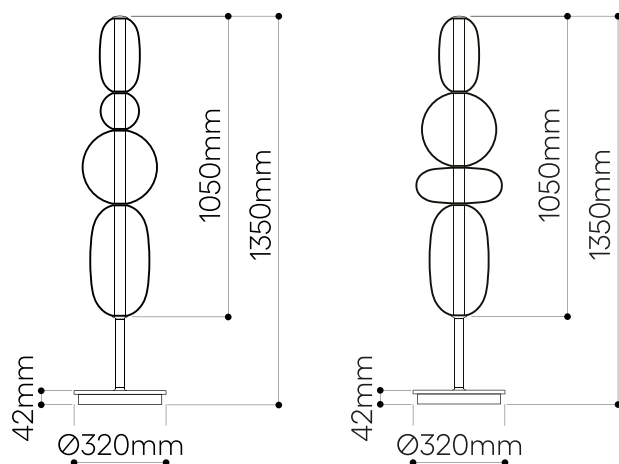

### LIGHTING DESCRIPTION

Size	dia 320 mm, H 1350 mm dia. 12,6 inch, H 53,15 inch
Cable	black textile braid cable 1,8 m / 70,8 inch
Weight	+ - 28 kg / 61,6 lb
Glass	mouth-blown lead-free crystal in black, light grey, white, green and red
Mounting	black (aluminium black elox + matt powder coating)
Protection	IP 20
Nominal voltage	220-240V A.C. 50-60 hz (EU) 110-120 V A.C. 60 Hz (USA)
Class	I. EU / I. USA

### LIGHT SOURCE

Type	LED module, 28W, 2800lm, 1050 mA, 27V
Base	custom LED module
Voltage	220-240V, AC (EU) / 110-120V, AC (USA)
Temperature	2700 K
Color index	RA 90+
Dimming	Dimmable with TRIAC, ELV, 0-10V, PUSH, DALI, CASSAMBI

### PACKAGING

Material	Cardboard
Size	2x 540 × 540 × 1550 mm 2x 21,3 × 21,3 × 61 inch

Origin: traditionally produced in the Czech Republic  
Intellectual property license holder: Bomma Czech Republic (EU)  
Represented by BMRC group s.r.o.

CERTIFICATES

