

Lightology

lightology.com
866-954-4489
04-24-26

Project: _____

Company: _____

Location: _____ Fixture Type: _____

SPEC #: **STM1088897**

Approved On: _____ Approved By: _____

Stratum Linear Pendant

By Studio M



Description

The eye-catching Stratum Linear Pendant is composed of thick glass slabs layered between discs finished in Natural Aged Brass. The arrangement hangs from faux leather straps that hide the electrical wiring, and concealed LED tubes evenly distribute light in all directions while highlighting the curved, offset glass outlines. Resembling gears and pulleys, this creatively designed pendant is a fascinating piece that elevates your lighting scheme. The 2022 Chicago Athenaeum Museum of Architecture & Design Good Design Award winner.

Specifications

COLOR	Clear
BODY FINISH	Natural Aged Brass
WATTAGE	10W
DIMMER	Low Voltage Electronic
DIMENSIONS	32"L x 4"W x 16"H
INTEGRATED LED MODULE	2 x LED/5W/120V LED
COUNTRY OF ORIGIN	China

Technical Information

PRODUCT DIMENSIONS	Adjustable Overall Height: 22" to 85"
LAMP LIFE	25000 hours
COLOR RENDERING	90 CRI
LAMP COLOR	3000K
LUMENS/WATT	90.00
LUMINOUS FLUX	450 lumens

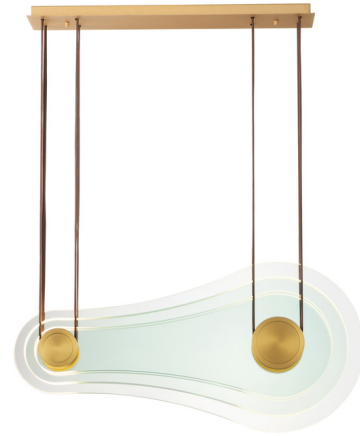

Shown in natural aged brass / clear

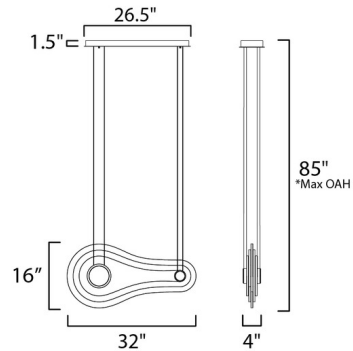

*max overall height



CLICK TO VIEW PRODUCT

Notes: