

# Lightology

lightology.com  
866-954-4489  
05-22-26

Project: \_\_\_\_\_

Company: \_\_\_\_\_

Location: \_\_\_\_\_ Fixture Type: \_\_\_\_\_

SPEC #: **RGNI182798**

Approved On: \_\_\_\_\_ Approved By: \_\_\_\_\_

## Andres Box Set By Regina Andrew

### Description

The Andres Box Set will stand out in any space with the unique texture of genuine hair on hide. Both stylish and functional, Andres will serve as a decorative object when it is not being used to store items. Due to natural variations in the hide, each basket is unique. Includes one set of two boxes.



Shown in grey hide

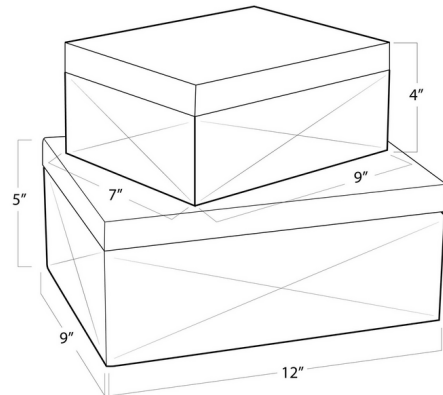

### Specifications

COLOR	N/A
BODY FINISH	Grey Hide
WATTAGE	N/A
DIMMER	N/A
DIMENSIONS	12"W x 5"H x 9"D
BULB	N/A
COUNTRY OF ORIGIN	India



CLICK TO VIEW PRODUCT

Notes: