

# Lightology

lightology.com  
866-954-4489  
05-20-26

Project: \_\_\_\_\_  
 Company: \_\_\_\_\_  
 Location: \_\_\_\_\_ Fixture Type: \_\_\_\_\_  
 SPEC #: **INV1233237**  
 Approved On: \_\_\_\_\_ Approved By: \_\_\_\_\_

## Malone Stem Hung Pendant

By Innovations Lighting



### Description

The Malone Stem Hung Pendant features a stunning water droplet-shaped glass shade that exudes elegance and fluidity. The organic curves of the droplet design evoke a sense of calm and refinement, perfectly complementing modern and transitional interiors. Its smooth, minimalist frame highlights the beauty of the glass, creating a captivating glow that enhances any kitchen, dining, or living space. NOTE: This is a stem hung pendant and includes 1-6 and 2-12 inch (1/2 diameter) stems.



Shown in matte black / clear

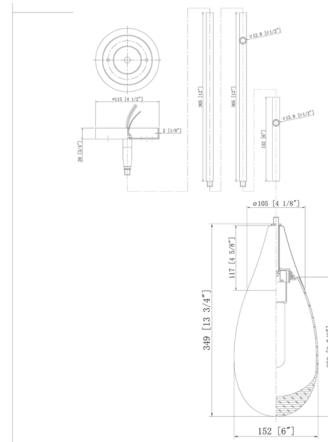

### Specifications

COLOR	Clear
BODY FINISH	Matte Black
WATTAGE	17W
DIMMER	Standard 120V
DIMENSIONS	6"W x 14.375"H
BULB NOT INCLUDED	1 x T9/Medium (E26)/17W/120V LED
COUNTRY OF ORIGIN	China

### Technical Information

PRODUCT DIMENSIONS . . . . . Downrods Included: (1) 6" and (2) 12" Stems



CLICK TO VIEW PRODUCT

Notes: