

Lightology

lightology.com
866-954-4489
04-25-26

Project: _____
 Company: _____
 Location: _____ Fixture Type: _____
 SPEC #: **STM1301721**
 Approved On: _____ Approved By: _____

Dreamer Linear Pendant By Studio M



Description

Drawing inspiration from her acclaimed Dreamcloud experiential design at Art Basel Miami, Nina Magon reinterprets her otherworldly installation for use in the home or hospitality project with the Dreamer Linear Pendant. The exaggerated curve, definitive of Magon's lighting design, suspends bubble-like glass forms that appear to float across channels of LED illumination. Dimmable via Triac, electronic low voltage (ELV) or 0-10V dimming.

Specifications

COLOR	Mirror Smoke
BODY FINISH	Black Chrome
WATTAGE	78W
DIMMER	Low Voltage Electronic
DIMENSIONS	35.75"L x 20"W x 48"H
INTEGRATED LED MODULE	4 x LED/19.5W/120-277V LED

Technical Information

PRODUCT DIMENSIONS	Canopy: 35.75"W x 19"D x 1.25"H
LAMP LIFE	20000 hours
COLOR RENDERING	90 CRI
LAMP COLOR	3000K
LUMENS/WATT	160.00
LUMINOUS FLUX	3120 lumens



Shown in black chrome / mirror smoke

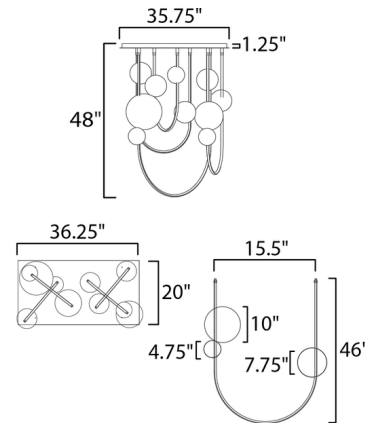

CLICK TO VIEW PRODUCT

Notes: