

# Lightology

lightology.com  
866-954-4489  
07-04-26

Project: \_\_\_\_\_

Company: \_\_\_\_\_

Location: \_\_\_\_\_ Fixture Type: \_\_\_\_\_

SPEC #: **STM1301757**

Approved On: \_\_\_\_\_ Approved By: \_\_\_\_\_

## Stratum Multi Light Linear Pendant

By Studio M



### Description

Clear slabs of glass a half inch thick are pressed together between two discs finished in Natural Aged Brass in the Stratum Multi Light Linear Pendant. As the glass approaches the center, each slab of glass increases in dimension creating a gradation of light revealing the glasses' shape and character. Dedicated LED lighting emits from concealed polycarbonate tubes evenly distributing the light source in all directions supported by Dark Brown leather straps that both suspend the pendants and conceal the electrical wiring stitched within them. Elevate your lighting to the next Stratum integrating bygone modern design elements with innovative technologies and expert craftsmanship. The 2022 Chicago Athenaeum Museum of Architecture & Design Good Design Award winner.

### Specifications

COLOR . . . . . Clear  
BODY FINISH . . . . . Natural Aged Brass  
WATTAGE . . . . . 60W  
DIMMER . . . . . Low Voltage Electronic  
DIMENSIONS . . . . . 61"L x 8.25"W x 26"H  
INTEGRATED LED MODULE . . . . . 6 x LED/10W/120V LED

### Technical Information

LAMP LIFE . . . . . 20000 hours  
COLOR RENDERING . . . . . 90 CRI  
LAMP COLOR . . . . . 3000K  
LUMENS/WATT . . . . . 240.00  
LUMINOUS FLUX . . . . . 2400 lumens



Shown in natural aged brass / clear

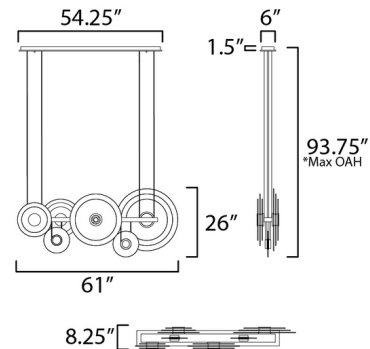

\*max overall height



CLICK TO VIEW PRODUCT

Notes: