

Lightology

lightology.com
866-954-4489
05-22-26

Project: _____

Company: _____

Location: _____ Fixture Type: _____

SPEC #: **HMR1417190**

Approved On: _____ Approved By: _____

Landmark Outdoor Post Light By Hammerton Studio



Description

The Landmark Outdoor Post Light brings a contemporary look to a classic lantern style. The band detailing surrounds beautiful hand blown hammered glass that casts warm shadows of light across your area. Standard post is required and sold separately below. The AAMA 2604-rated finishes provide long-lasting UV and corrosion resistance in coastal and other harsh climates and have a lifetime warranty.



Shown in textured black / clear hammered

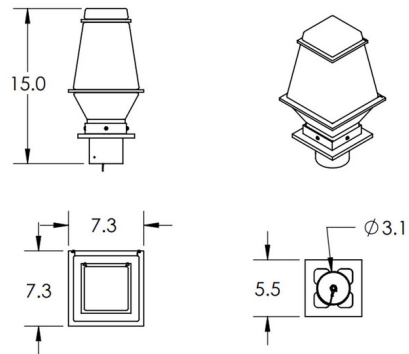

Mounting Method: Mounts Directly To Post

Specifications

COLOR Clear Hammered
BODY FINISH Textured Black
WATTAGE 12W
DIMMER Standard 120V
DIMENSIONS 7.3"W x 15"H
BULB NOT INCLUDED 1 x A19/Medium (E26)/12W/120V LED



CLICK TO VIEW PRODUCT

Notes: