

Lightology

lightology.com
866-954-4489
05-24-26

Project: _____

Company: _____

Location: _____ Fixture Type: _____

SPEC #: **ET21419198**

Approved On: _____ Approved By: _____

Nimbus Multi-Light Pendant

By Et2



Description

The Nimbus Multi-Light Pendant features an elegant constellation of patterned glass. Each globe is oblong in shape, with a marble swirl that obscures the integrated LED lighting within. Thin black electrical cords are easily adjustable, allowing the height of each pendant to be individually set.

Specifications

COLOR White
 BODY FINISH Black
 WATTAGE 21W
 DIMMER Low Voltage Electronic
 DIMENSIONS 20.5"W x 8"H
 INTEGRATED LED MODULE 3 x LED/7W/120-277V LED

Technical Information

LAMP LIFE 50000 hours
 COLOR RENDERING 90 CRI
 LAMP COLOR 3000K
 LUMENS/WATT 240.00
 LUMINOUS FLUX 1680 lumens



Shown in black / white

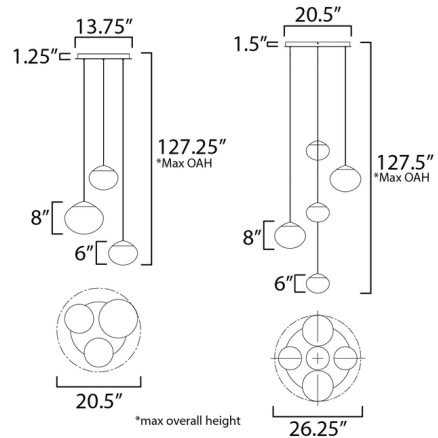

CLICK TO VIEW PRODUCT

Notes: