

Lightology

lightology.com
866-954-4489
06-04-26

Project: _____
 Company: _____
 Location: _____ Fixture Type: _____
 SPEC #: **ART1428396**
 Approved On: _____ Approved By: _____

Discovery Suspension - Floor Model

By Artemide



Description

The Discovery Suspension is an extraordinary lighting fixture, born from a philosophy of minimal geometry and magical illumination. A slim ring artfully houses an LED strip that injects light into a specially worked surface of transparent PMMA. The true marvel of the Discovery lies in its diffuser, composed of a perfectly transparent PMMA surface embedded with micro-particles so minuscule that the surface is hardly perceptible when the fixture is turned off. However, when the fixture is illuminated, the transparent interior appears to miraculously fill with light, as if by magic. This unique result is achieved through Discovery's innovative direct and indirect emissions, which produce an embracing and uniform light throughout the entire surface, creating an ethereal glow that envelops the space. The geometry and layout of these micro-particles are precisely calculated to ensure a constant and even emission of light across the entire surface.

Specifications

COLOR	Transparent
BODY FINISH	Polished Aluminum
WATTAGE	49.3W
DIMMER	Low Voltage Electronic
DIMENSIONS	27.6"W x 31.5"H
INTEGRATED LED MODULE	1 x LED/49.3W/120-277V LED
COUNTRY OF ORIGIN	Italy

Technical Information

PRODUCT DIMENSIONS	Canopy: 9.6" diameter
LAMP LIFE	50000 hours
COLOR RENDERING	90 CRI
LAMP COLOR	3000K
LUMENS/WATT	57.51
LUMINOUS FLUX	2835 lumens



Shown in polished aluminum / transparent

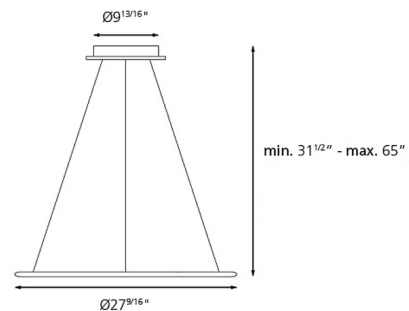

CLICK TO VIEW PRODUCT

Notes: