

Lightology

lightology.com
866-954-4489
04-18-26

Project: _____

Company: _____

Location: _____ Fixture Type: _____

SPEC #: **KUN1533018**

Approved On: _____ Approved By: _____

Mitos Cable Holder

By kdIn

Description

The Mitos Cable Holder is an accessory for the Mitos Modular Spot Light system by kdIn. The cable holder can be used to anchor the copper cables that link the spot lights to the wall or ceiling.

Specifications

COLOR	N/A
BODY FINISH	Black
WATTAGE	N/A
DIMMER	N/A
DIMENSIONS	3"W x 0.3"H x 0.8"D
BULB	N/A

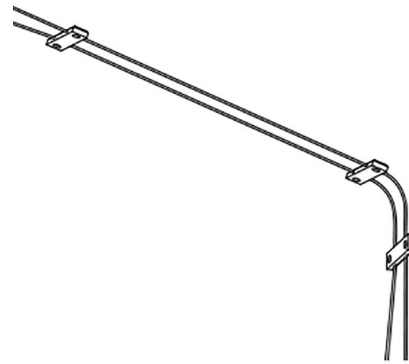

Shown in black

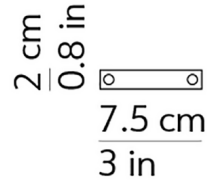

CLICK TO VIEW PRODUCT

Notes: