



BRAND

Hadco by Signify

DESCRIPTION

IUL516 LED Composite Inground Uplight is fabricated from one piece injection molded high performance polymer composite. Composite is textured, pressure formed, molded in color in Bronze. Lens ring is a single piece injection molded high performance polymer with gasketed lens and twist off operation for ease of maintenance. Clear convex, tempered glass furnished with silicone O-ring for watertight seal. Includes one 7 watt 12 volt GU5.3 MR16 LED lamp with 25 degree beam spread, 3000K color temperature, 460 lumens. 25,000 hour average lamp life. Pre-wired with 3 foot pigtail of 18-2 AWG wire. Includes low voltage quick connector LVC3 for easy hook up to the low voltage supply cable, sold separately. 4.1 inch diameter x 4.4 inch height. ETL listed for wet locations. 5 year limited warranty. Requires remote transformer, sold separately.



Shown in: Bronze

| | |
|----------------------|-----------------------------------|
| SHADE COLOR | N/A |
| BODY FINISH | Bronze |
| WATTAGE | 7W |
| DIMMER | Dimmable |
| DIMENSIONS | 4.1"W x 4.4"H |
| BULB INCLUDED | |
| LAMP | 1 x MR16/GU5.3 (bipin)/7W/12V LED |

Technical Information

| | |
|----------------------|------------|
| LUMINOUS FLUX | 460 lumens |
| LUMENS/WATT | 65.71 |
| LAMP COLOR | 3000K |
| BEAM ANGLE | 25° |

SPEC # HAD400558

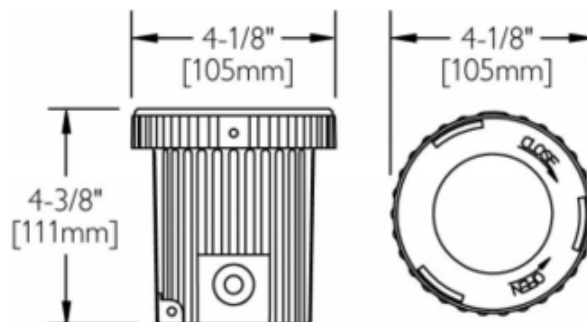

| COMPANY | PROJECT | FIXTURE TYPE | APPROVED BY | DATE |
|---------|---------|--------------|-------------|------|
| | | | | |