

**BRAND**

Brand Van Egmond

**DESCRIPTION**

The Flintstone Floor Lamp returns to the beginning of times, back at the fireplace in the prehistoric cave. The tree branch and the stone, found at the end of this journey, are combined in this lighting object. Every stone is unique, and captures the emotion of eternity as well as being used as a functional counterweight. The branch arm of the Flintstone is movable, allowing the light to be adjusted and easily moved through space. Flintstone Floor Lamp features Black, Brass Burnished, White or Nickel finish. On/off switch located on the lamp's cord.



Shown in: Nickel

|                          |                                  |
|--------------------------|----------------------------------|
| <b>SHADE COLOR</b>       | N/A                              |
| <b>BODY FINISH</b>       | Nickel                           |
| <b>WATTAGE</b>           | 6W                               |
| <b>DIMMER</b>            | Included                         |
| <b>DIMENSIONS</b>        | 27.6"W x 92.6"H x 15.8"D         |
| <b>BULB NOT INCLUDED</b> |                                  |
| <b>LAMP</b>              | 1 x A19/Medium (E26)/6W/120V LED |

*Technical Information*

|                           |                    |
|---------------------------|--------------------|
| <b>PRODUCT DIMENSIONS</b> | Cord Length: 78.7" |
|---------------------------|--------------------|

**SPEC #** BVE449192

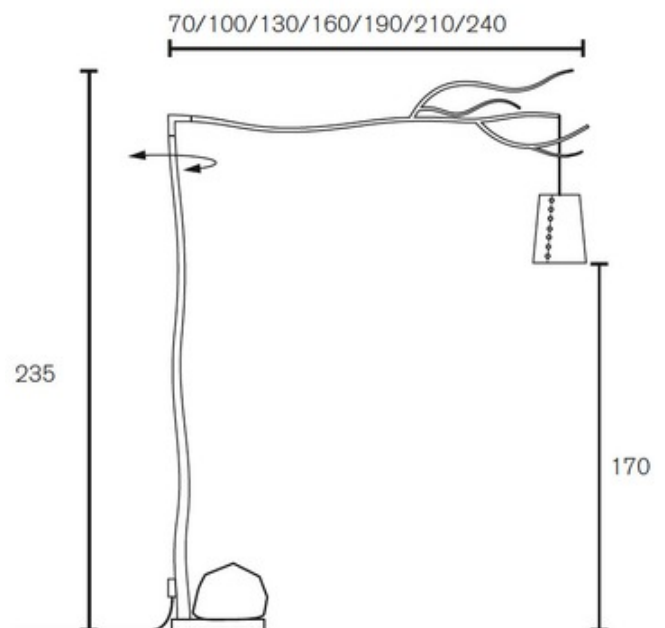

| COMPANY | PROJECT | FIXTURE TYPE | APPROVED BY | DATE |
|---------|---------|--------------|-------------|------|
|         |         |              |             |      |