



DESIGNER

Constance Guisset

BRAND

Petite Friture

DESCRIPTION

The Vertigo Pendant is simultaneously ethereal and graphic, adapting to both large and small spaces where it creates it's own intimate space. With its ultra light fiberglass structure, stretched with velvety polyurethane ribbons, this pendant lamp fascinates as it comes to life swaying in the soft air currents that surround it.



Shown in: Black / Black

SHADE COLOR	Black
BODY FINISH	Black
WATTAGE	40W
DIMMER	Standard 120V
DIMENSIONS	55.2"W x 6"H
BULB NOT INCLUDED	
LAMP	1 x G30/Medium (E26)/40W/120V Incandescent 1 x G30/Medium (E26)/120V LED

Technical Information

PRODUCT DIMENSIONS	Canopy: 4.7" diameter
---------------------------	-----------------------

SPEC #

PFT571872

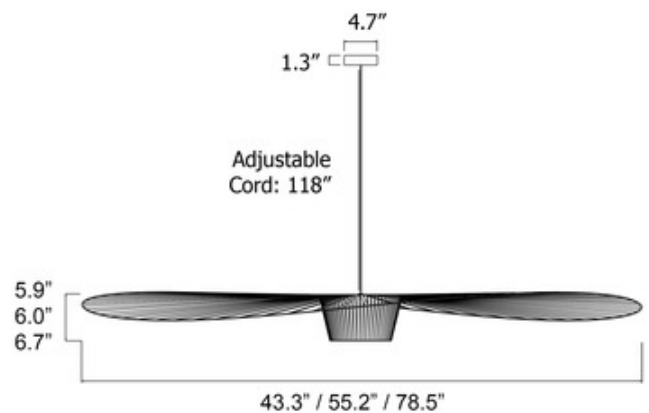

COMPANY

PROJECT

FIXTURE TYPE

APPROVED BY

DATE