

# Lightology

lightology.com  
866-954-4489  
07-08-26

Project: \_\_\_\_\_  
 Company: \_\_\_\_\_  
 Location: \_\_\_\_\_ Fixture Type: \_\_\_\_\_  
 SPEC #: **CER880070**  
 Approved On: \_\_\_\_\_ Approved By: \_\_\_\_\_

## Tersus Outdoor Downlight Wall Sconce By Cerno



### Description

The Tersus Outdoor Downlight Wall Sconce is an example of the simplest form unlocking a myriad of design possibilities, providing downlight to accent a variety of exterior spaces. Option of 2700, 3000, 3500, or 4000K color temperature with standard output (1130 lumens) or reduced output (540 lumens). Standard output dimmable with a TRIAC or electronic low voltage dimmer at 120V or 0-10V dimmer at 277V. Reduced output option is not dimmable. 2700K and 3000K options Dark Sky compliant.

### Specifications

COLOR	N/A
BODY FINISH	Marine Grade Brushed Stainless Steel
WATTAGE	14W
DIMMER	Not Dimmable
DIMENSIONS	7.25"W x 10.75"H x 2.75"D
INTEGRATED LED MODULE	1 x LED/14W/120-277V LED
COUNTRY OF ORIGIN	United States

### Technical Information

COLOR RENDERING	90 CRI
LAMP COLOR	3500K
LUMENS/WATT	38.57
LUMINOUS FLUX	540 lumens



Shown in marine grade brushed stainless steel

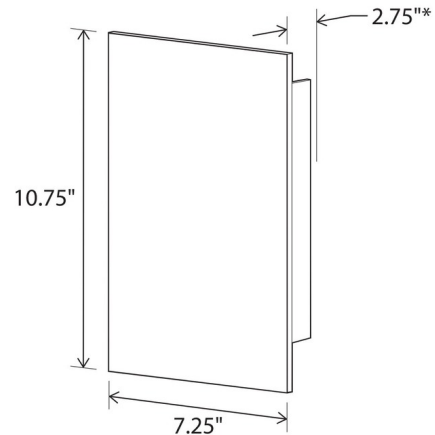

CLICK TO VIEW PRODUCT

Notes: