

Lightology

lightology.com
866-954-4489
06-04-26

Project: _____

Company: _____

Location: _____ Fixture Type: _____

SPEC #: **ELE931293**

Approved On: _____ Approved By: _____

1X1 Trimmed Flangeless Chicago Plenum Non-IC Housing

By Visual Comfort Architectural



Description

1X1 Flangeless 1-Light Chicago Plenum Non-IC Housing is constructed of heavy gauge cold rolled steel with durable Black or White powder coat finish. Available in a low output (2 x 12 watt) or high output (2 x 17 watt) option. Features a unique patented LED spot dome module enabling tool-free adjustment and locking while maintaining center beam through the aperture. 35 degree tilt, 360 degree rotation. Low profile design for use in standard 2X6 construction. Accommodates up to 2 inch ceiling thickness. Includes integrated junction box approved for branch circuit through wiring. Housing includes individual driver for each module (ie: 1 driver in a 1x1). Flangeless housing includes extruded and precision welded aluminum plaster plate. 5 inch x 5 inch ceiling cut-out per module. ETL listed. Suitable for damp locations. 5 year warranty. Dimming Options: Electronic low voltage (ELV) down to

Specifications

REFLECTOR/BAFFLE COLOR	N/A
BODY FINISH	Black
WATTAGE	12W
DIMMER	Low Voltage Electronic
DIMENSIONS	9.9"L x 7.5"W x 5.8"H
INTEGRATED LED MODULE	1 x LED/12W/120-277V LED

Technical Information

APERTURE SIZE	2.800"
APERTURE SHAPE	Square
HOUSING HEIGHT	6"
HOUSING TYPE	Chicago plenum approved
CEILING TYPE	Drywall Trimless/Flush
LUMENS/WATT	104.00
LUMINOUS FLUX	1248 lumens

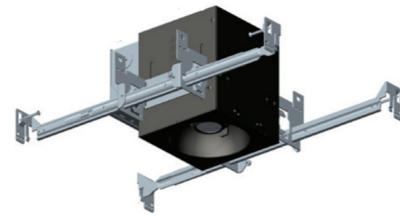

Shown in black

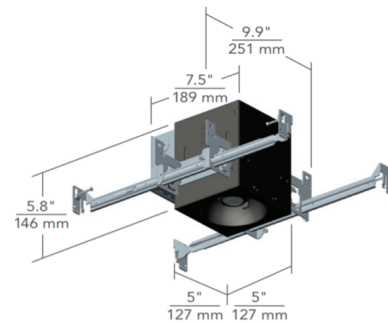

CLICK TO VIEW PRODUCT

Notes: