



**BRAND**

Contardi

**DESCRIPTION**

The Calypso Martinique Outdoor Pendant is a collection of lamps inspired by the forties. They show a connection with the tropical and Southern American world, where the European deco style, characterized by geometric lines and black and whites, is twisted and revitalized thanks to bright colors, patterns, and twine. Includes a moss green waterproof braided suspension cord. Note: Large option not available in Building Multi color. The fabrics used for the outdoor collection are waterproof and/or water repellent.



Shown in: Satin Brass / Yellow Multi

<b>SHADE COLOR</b>	Yellow Multi
<b>BODY FINISH</b>	Satin Brass
<b>WATTAGE</b>	9W
<b>DIMMER</b>	Low Voltage Electronic
<b>DIMENSIONS</b>	27.5"W x 24.8"H
<b>BULB NOT INCLUDED</b>	
<b>LAMP</b>	1 x T8/Medium (E26)/9W/120V LED

*Technical Information*

<b>LAMP COLOR</b>	2100K
<b>COLOR RENDERING</b>	90 CRI
<b>PRODUCT DIMENSIONS</b>	Cable Length: 78.7"

**SPEC #** CDI959472

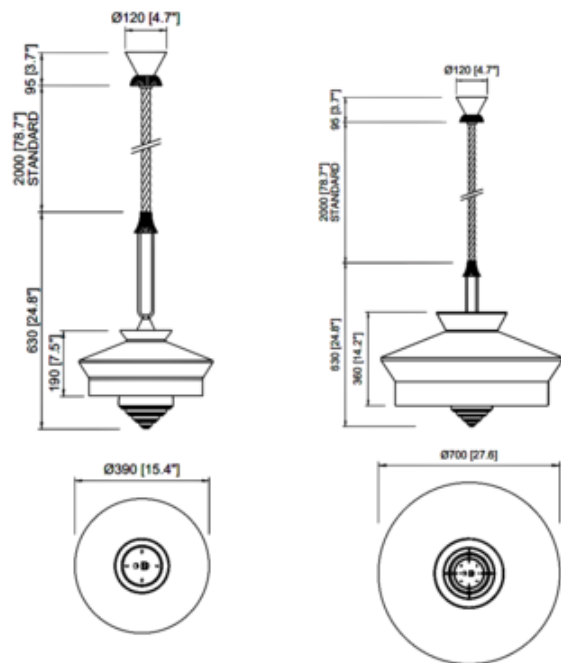

COMPANY	PROJECT	FIXTURE TYPE	APPROVED BY	DATE